



**CLEAN DEVELOPMENT MECHANISM
PROJECT DESIGN DOCUMENT FORM (CDM-PDD)
Version 03 - in effect as of: 28 July 2006**

CONTENTS

- A. General description of project activity
- B. Application of a baseline and monitoring methodology.
- C. Duration of the project activity / crediting period
- D. Environmental impacts
- E. Stakeholders' comments

Annexes

- Annex 1: Contact information on participants in the project activity
- Annex 2: Information regarding public funding
- Annex 3: Baseline information
- Annex 4: Monitoring plan

**SECTION A. General description of project activity****A.1 Title of the project activity:**

>>

Emission reductions through partial substitution of fossil fuel with alternative fuels in the 2 cement plants of PT Holcim Indonesia Tbk.

Version 01, 27/04/2007

A.2. Description of the project activity:

>>

The project activity consists of a partial replacement of coal in the kiln system by alternative fuels like biomass (palm kern shell, rice husk, saw dust, etc.) and potentially a smaller quantity of sorted waste (rubbers, plastics, paper, etc.). The purpose of the project activity is to reduce CO₂ emissions generated from fuel burning requirement in the cement manufacturing.

The project is implemented in the 2 cement plants of PT Holcim Indonesia Tbk (HIL) located in Cilacap and Narogong. The project activity aims to replace about 34% of the heat requirement with alternative fuels.

Clinker manufacturing, and therefore cement manufacturing, is a highly, energy-intensive process. The pyro-processing stage, i.e., where the raw material is heated to a temperature that leads to the key mineralogical change that forms clinker, requires the largest amount of heat in the total cement manufacturing activity. The use of biomass and sorted waste as alternative sources of thermal energy to manufacture the clinker will result in a significant economy on non-renewable fossil fuels.

In addition to the saving of non renewable resource and as a contribution to sustainable development in Indonesia, the project will carry several environmental improvements and socio-economic benefits such as:

- To offer business and employment opportunities

The biomass supply chains such as collecting, pre-processing and transporting are employment demanding, thus creating business opportunities.

- To increase the capital

The use of agricultural wastes that were previously burned in open air or left to decay without any value will create new income sources. The biomass business will generate additional revenues and direct cash flow to the transporters, millers and farmers, increasing their economic status and social well-being.

- To offer an alternative solution to biomass disposal issues

As agricultural wastes are available in large quantity in Indonesia, the disposal of these materials are challenging. Most of them are temporarily stocked, piled and burned in open air when the disposal becomes too problematic. By using this material as fuel, HIL adds a value and helps the local environment with a proper disposal.



The project activity will support sustainable development in Indonesia and more specifically in the 2 regions bordered by the project. The volume of non-renewable fuels necessitated by the cement manufacturing process will be reduced and consequently economised. The project activity generally contributes to the health of the community by helping to lift the environmental and the socio-economic level of the regions.

A.3. Project participants:

>>

Name of Party involved	Private and/or public entity (ies) project participants (as applicable)	Kindly indicate if the Party involved wishes to be considered as a project participant
Indonesia (host)	Private entity: PT Holcim Indonesia Tbk	No
Switzerland	Private entity: Holcim Group Support Ltd	No

A.4. Technical description of the project activity:

A.4.1. Location of the project activity:

>>



**A.4.1.1. Host Party(ies):**

>>

Indonesia

A.4.1.2. Region/State/Province etc.:

>>

Cilacap Plant: Java Tengah

Narogong Plant: Java Barat

A.4.1.3. City/Town/Community etc:

>>

Cilacap Plant: Cilacap

Narogong Plant: Bogor

A.4.1.4. Detail of physical location, including information allowing the unique identification of this project activity (maximum one page):

>>

PT Holcim Indonesia Tbk

Cilacap Plant

Jl. Ir. H. Juanda

P.O. Box 272 Cilacap

53234 Cilacap

Indonesia

PT Holcim Indonesia Tbk

Narogong Plant

Jl. Raya Narogong Km. 7

P.O.Box 25 Bogor

16820 Bogor

Indonesia

A.4.2. Category(ies) of project activity:

>>

Manufacturing Industries

A.4.3. Technology to be employed by the project activity:

>>

The technologies employed to co-process the alternative fuels has been developed by HIL with the support of experts from the Holcim Group. The department of alternative fuels and raw materials (AFR) of Holcim Group provides an insight into state of the art technologies, exchange experiences in the alternative fuels selection and design of installations, develops tools to limit the impact on production loss and clinker quality and establishes quality control procedures.



A similar system will be set up in the 2 plants respectively in one operating kiln system in Cilacap (CC2) and in two operating kilns in Narogong (NR3 and NR4). The system to be used will be set up in different segments regarding specific investments and planning.

The first segment aims to install a specific feeding system for the 3 kilns with a dedicated covered area to receive the alternative fuels. The materials will be fed to the calciners. The second segment includes feeding installations which allow the co-processing through the main burner and the third segment aims to increase the capacity by optimizing the installations.

A fourth segment which is not yet defined has the goal to increase the coal replacement at a highest level. Since this last segment is still imprecise, the current calculation and forecast are done with the aim to replace to about 34% of the energy requirement by alternative fuels.

The figure bellow shows the feeding system that will be set-up in the 3 kilns.

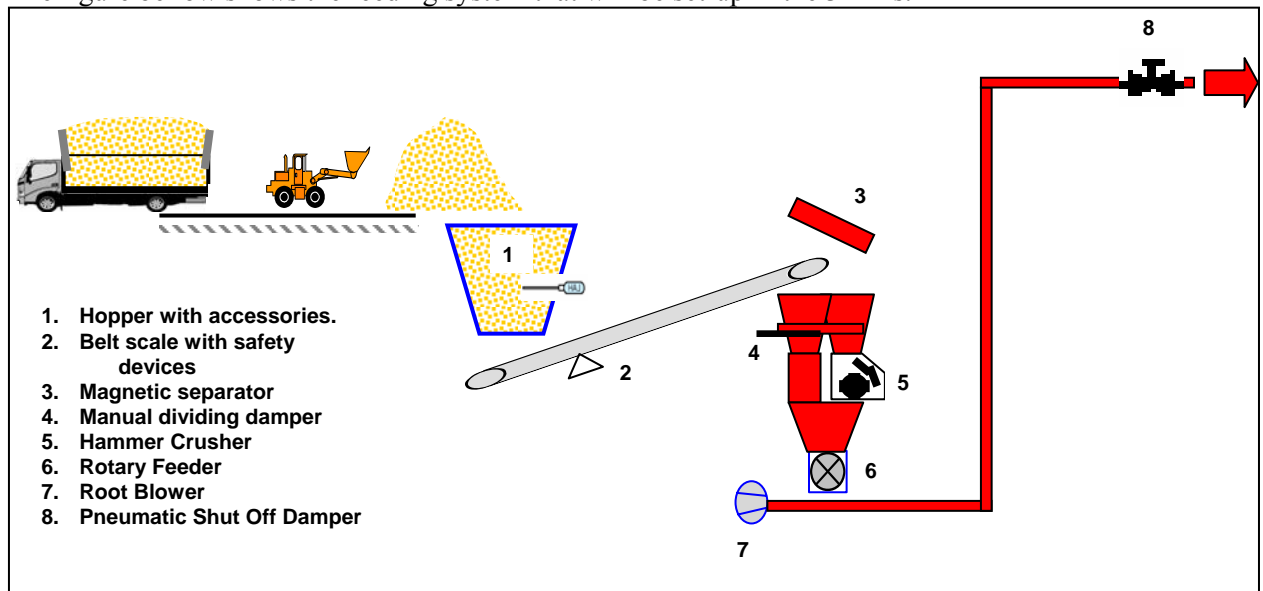

The figure bellows show the feeding points which are going to be equipped through the duration of the project activity.

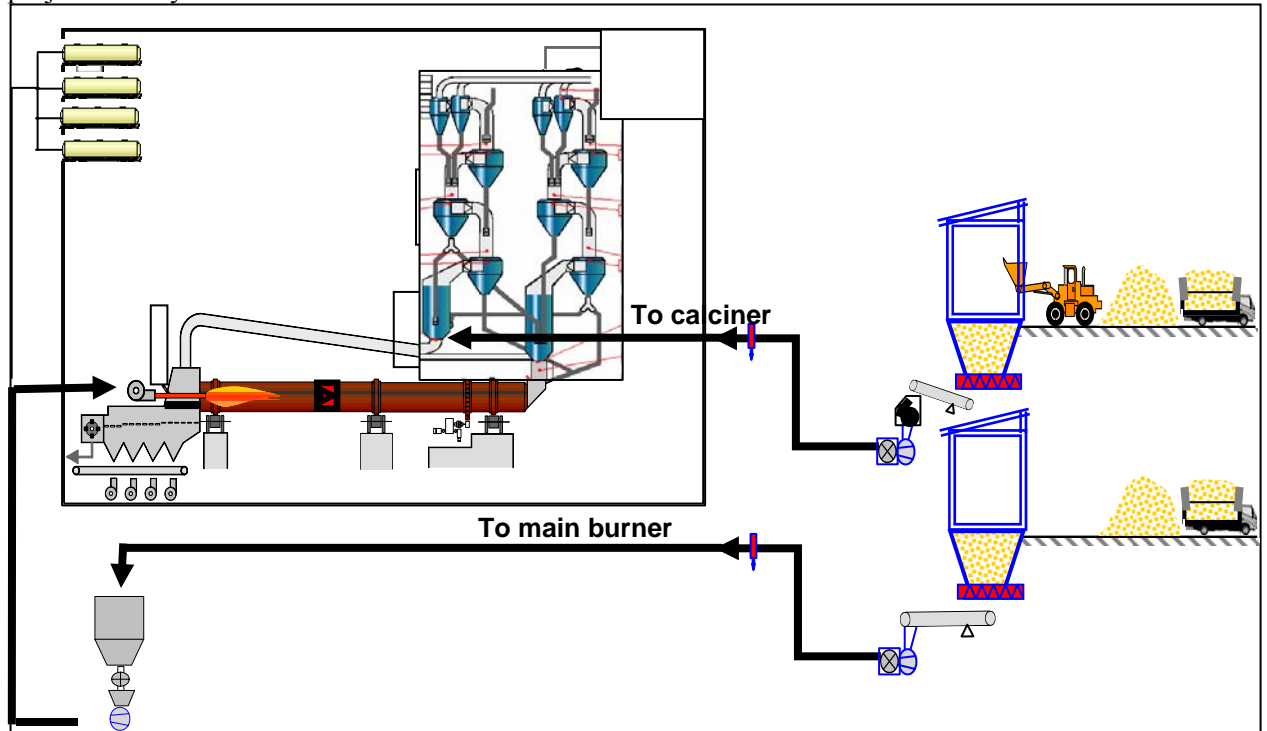

A.4.4 Estimated amount of emission reductions over the chosen crediting period:

>>

A crediting period of 10 years has been chosen for the project activity.

Year	Annual estimation of emission reductions in tonnes of CO2 Narogong (NR)	Annual estimation of emission reductions in tonnes of CO2 Cilacap (CC)	Annual estimation of emission reductions in tonnes of CO2 Total
Year A (2007)	35,037	59,570	94,607
Year B	78,040	75,393	153,433
Year C	123,237	132,753	255,990
Year D	224,312	182,912	407,225
Year E	366,242	237,975	604,218
Year F	366,242	237,975	604,218
Year G	366,242	237,975	604,218
Year H	366,242	237,975	604,218
Year I	366,242	237,975	604,218
Year J	366,242	237,975	604,218
Total estimated reductions	2,658,081	1,878,480	



(tonnes of CO ₂ e)			
Total number of crediting years	10	10	10
Annual average over the crediting period of estimated reductions (tonnes of CO₂e)	265,808	187,848	453,656

A.4.5. Public funding of the project activity:

>>

The project activity has received no public funding.

B.1. Title and reference of the approved baseline and monitoring methodology applied to the project activity:

>>

ACM0003 / Version 04

Approved baseline methodology and approved monitoring methodology “Emissions reduction through partial substitution of fossil fuels with alternative fuels in cement manufacture”.

B.2 Justification of the choice of the methodology and why it is applicable to the project activity:

>>

The approved baseline methodology ACM0003 is appropriate for HIL’s project activity since all the applicability conditions are fulfilled.

The applicability is justified in the following:

- Fossil fuels used in clinker manufacturing are partially replaced with biomass residues (Palm Kernel Shell, rice husk, saw dust and other possible agricultural wastes.) and potentially a small amount of sorted waste (rubbers, plastics, papers, etc.).
- The biomass residues are available as an excess by-product and, in the absence of the project activity, would be burned in an uncontrolled manner without utilizing them for energy purpose.
- The biomass residue used by the project activity doesn’t necessitate a preparation requiring significant energy quantity. The only energy requirement related to the use of biomass residues is due to transportation.
- CO₂ emission reductions are only related to the CO₂ emissions generated by fuel burning requirement and not by decarbonisation of raw material.



- The methodology is applicable for the currently installed capacity presented below.

Cilacap (CC2): 7,800 tonnes of clinker/day

Narongong (NR3 and NR4): 12,400 tonnes of clinker/day

- The amount of alternative fuels available is at least 1.5 times the amount required to meet the consumption of all users consuming the same alternative fuels.

Biomass is the main alternative fuel proposed in the project activity. The official report: “Biomass Energy Potentials and Utilization in Indonesia”¹ written by the Laboratory of Energy and Agricultural Electrification, the Department of Agricultural Engineering and the Indonesian Renewable Energy Society shows that biomass is plentifully available in Indonesia.

The table below shows an extract of the main alternative fuels proposed to be used in the project activity:

Biomass	Main region	Official availability¹ in the region per year (t)	Average proposed to be used by he project per year during the crediting period (t)
Palm kernel shell	Sumatra, Kalimantan, Sulawesi, Maluku, Nusa, Tenggara, Irian Jaya	1,200,000	155,356
Rice husk	Java, Sumatera, Kalimantan, Irian Jaya, Maluku	12,000,000	168,121
Wood residues (incl. saw dust)	Java, Sumatera, Kalimantan, Irian Jaya, Maluku	7,300,000	53,428

¹Source: ZREU, CGI 2000 .

¹ KAMARUDDIN ABDULLAH, Biomass Energy Potentials and Utilization In Indonesia. Laboratory of Energy and Agricultural Electrification, Department of Agricultural Engineering, IPB And Indonesian Renewable Energy Society (IRES), PO Box 220, Darmaga Campus of IPB, Darmaga, Bogor, 16002. Indonesia, Tel./Fax.: +62 251 621886/7; E-mail: kdin@bogor.wasantara.net.id

B.3. Description of the sources and gases included in the project boundary

>>

The figure below shows the cement manufacturing process. The physical project boundary covers all production processes related to clinker production.

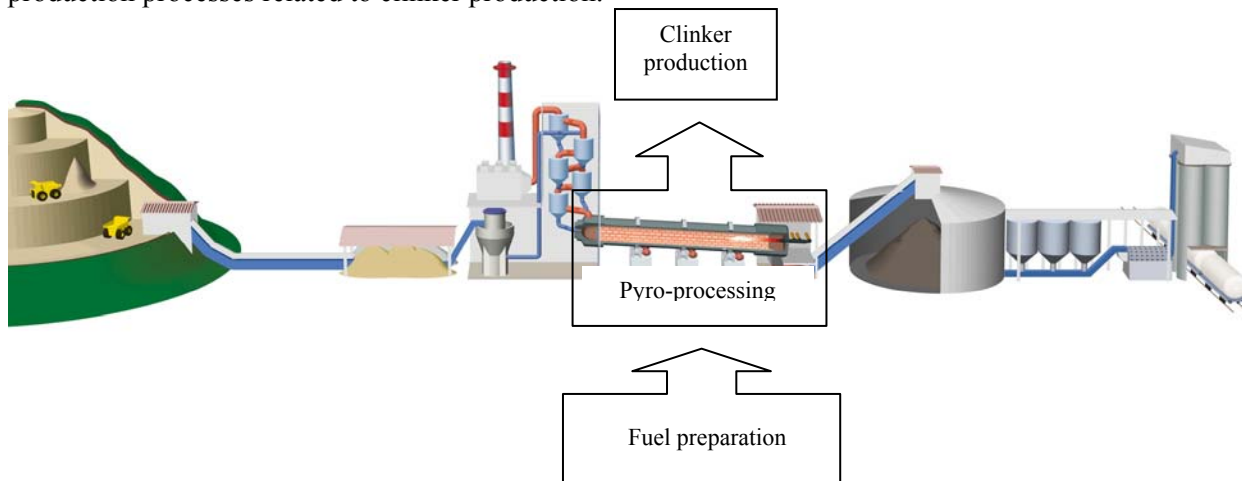

The table below shows that CO₂ emissions from the combustion of fuels and from the fuel transportation and preparation are considered for the purpose of calculating project emissions and baseline emissions.

	Source	Gas	Included?	Justification / Explanation
Baseline	Kiln fuel use	CO ₂	YES	Direct emissions from firing the kiln and processing
		CH ₄	NO	CH ₄ emissions from combustion processes are considered negligible and excluded because these emissions by the cement industry are negligible (see WBCSD / WRI Cement protocol)
		N ₂ O	NO	N ₂ O emissions from combustion processes are considered negligible and excluded because these emissions by the cement industry are negligible (see WBCSD / WRI Cement protocol)
Project activity	Kiln fuel use	CO ₂	YES	Direct emissions from firing the kiln and processing (including supplemental fuels used in the precalciner)
		CH ₄	NO	CH ₄ emissions from combustion processes are considered negligible and excluded because these emissions by the cement industry are negligible (see WBCSD / WRI Cement protocol)
		N ₂ O	NO	N ₂ O emissions from combustion processes are considered negligible and excluded because these emissions by the cement



				industry are negligible (see WBCSD / WRI Cement protocol)
	On site transportation and preparation of alternative fuels	CO ₂	YES	Direct emissions due to AF transportation and indirect emissions from fossil fuels combustion of power plants from the grid due to electricity used.
		CH ₄	NO	negligible
		N ₂ O	NO	negligible

Additional emissions are included in the project activity as leakage:

- Emissions (CH₄) due to biomass residues that would be burned in the absence of the project activity.
- Emissions (CO₂) from off site transportation of alternative fuels (reduction of fossil fuels transportation are neglected to be conservative).
- Emissions (CO₂) from off site preparation of alternative fuels.

B.4. Description of how the baseline scenario is identified and description of the identified baseline scenario:

>>

Baseline scenario selection

Baseline scenario 1: Continuation of the current practice

HIL is using coal in order to manufacture the clinker. It is also common practice in HIL to utilize light oil or diesel as well as used fuel to start up the kiln.

The table below shows in percentage of the heat consumption the fuel mix for the year 2004, i.e the year before the tests and trials and for the year 2005.

Average	Coal (%)	Light oil/diesel (%)	Used fuel (%)	Trial materials
2004	93.88	5.37	0.75	0.00
2005	96.24	2.10	0.74	0.92

The cement manufacturing industries in Indonesia are also mainly using coal. In this regard, continuing utilization of fossil fuel, including used fuel, is most likely to happen in the absence of the project activity. There is no legal obligation for cement companies in Indonesia to use alternative fuels and indigenous coals are available, reliable and sold at low cost. Major barriers restraint the use of alternative fuels such investments for the infrastructures and know-how to co-process regarding the standards quality and the production losses.

The baseline scenario 1 “continuation of the current practice” is therefore based on the fuel mix in 2005 without the trial materials.

	Coal (%)	Light oil/diesel (%)	Used fuel (%)
Average	97.05	2.15	0.80

Baseline scenario 2: Evolving Fuel mix



Regarding the WBCSD and IEA statistics², the fuel mix in cement industry in South East Asia is 82% coal, 9% oil, 8% gas and 1% other. Indonesia gas developers try as well in this direction to penetrate the market. In this view, we could envision a similar mix portfolio.

However, the gas network is still underdeveloped in Indonesia. The gas is an expensive option and the lack of infrastructure makes this switch relatively impossible over the project period. In this direction, the World Bank³ has stated that power generation and cement industry in Indonesia are going, in the next years, to increase their reliance on coal. Indeed, HIL will most likely continue to mainly use coal and therefore the scenario 2 is excluded in the further analysis.

Baseline scenario 3: Substitution of fossil fuel with alternative fuels (i.e the proposed CDM project activity)

The third baseline is the project activity i.e using alternative fuels to replace partially fossil fuels.

In regard to start the project activity, test and trials were done in 2005.

With considerable investment in new infrastructures plus know how development and transfer, the project would enable HIL to co-process a significant amount of biomass and potentially a smaller amount of sorted waste. The amount of alternative fuels is presently estimated to 34% with an opening for larger replacement.

The table below shows, in percentage, the HIL's fuel mix composition for the proposed project activity (average for the 2 plants):

HIL	2007	2008	2009	2010	2011	2012	2013	2014	2015	2016
Coal	90.55	87.22	81.26	73.39	63.09	63.09	63.09	63.09	63.09	63.09
Light oil /Diesel	2.13	2.14	2.14	2.14	2.14	2.14	2.14	2.14	2.14	2.14
Used fuel	0.78	0.76	0.76	0.76	0.75	0.75	0.75	0.75	0.75	0.75
CPO	0.60	0.60	0.60	0.60	0.60	0.60	0.60	0.60	0.60	0.60
Biomass	5.94	9.28	15.24	23.11	33.41	33.41	33.41	33.41	33.41	33.41
Sorted waste	nd	nd	nd	nd	nd	nd	nd	nd	nd	nd

The biomass to be co-processed will be mainly PKS, rice husk and saw dust. The table bellow shows the percentage of each alternative fuels.

Biomass	2007	2008	2009	2010	2011	2012	2013	2014	2015	2016
PKS	2.13	3.38	6.68	10.26	18.14	18.14	18.14	18.14	18.14	18.14
rice husk	2.37	3.72	6.01	10.66	12.54	12.54	12.54	12.54	12.54	12.54

² Michael Taylor, Cecilia Tam and Dolf Gielen, Energy Efficiency and CO2 Emissions from the Global Cement Industry. Energy Technology Policy Division. International Energy Agency. Draft version 30/8/2006. Paper prepared for the IEA-WBCSD workshop: Energy Efficiency and CO2 Emission Reduction Potentials and Policies in the Cement Industry, IEA, Paris, 4-5 September 2006.

³<http://web.worldbank.org/WBSITE/EXTERNAL/COUNTRIES/EASTASIAPACIFICEXT/EXTEAPREGTOPENERGY/0,,contentMDK:20506301~pagePK:34004173~piPK:34003707~theSitePK:574015,00.html>



saw dust	1.43	2.18	2.54	2.19	2.73	2.73	2.73	2.73	2.73	2.73
Total	5.94	9.28	15.24	23.11	33.41	33.41	33.41	33.41	33.41	33.41

Since the amount of fossil fuel replacement by alternative fuels is slightly different for each plant and each kiln, separate emission reduction calculations are handled in the calculation data base.

Baseline scenario selection

Option 2: Select baseline scenario through barriers analysis

Alternative scenario	Investment barriers	Technological barriers	Barriers due to prevailing practices	Other barriers
Scenario 1	No initial capital investment required	No additional technological barriers. The plants will operate with this scenario in the absence of the project activity.	This is the prevailing practice	No
Scenario 3	Large capital investment	1) New installations and optimization of the technical components are required.	Know how of co-processing has to be acquired and operators have to be trained with handling and feeding of alternative fuels.	The use of alternative fuels reduces the production capacity, increase the down time and increase the maintenance cost.

Based on the above barriers analysis, scenario 1 is most likely to happen in the absence of the proposed project activity. Indeed, there is no investment, no additional technological barriers and it is the prevailing practice. Therefore, scenario 1 is selected as the baseline scenario.

The data for the baseline estimation stems from the annual technical report (ATR) of the 2 HIL's cement plants i.e. Cilacap (kiln CC2) and Narogong (kilns NR3 and NR4).

Description of the selected baseline

Since each kiln has a slightly different fossil fuel mix, a specific baseline in percentage of heat requirement is defined for each kiln regarding the selected scenario (i.e., scenario 1).

Fuel	Cilacap (CC2)	Narogong (NR3)	Narogong (NR4)
Coal	97.85	93.67	98.29
Light oil/ Diesel	2.15	2.87	1.71
Waste oil	0.00	3.46	0.00

B.5. Description of how the anthropogenic emissions of GHG by sources are reduced below those that would have occurred in the absence of the registered CDM project activity (assessment and demonstration of additionality): >>



2007	1,390	1,013	169	844	253	760	(630)	
2008	12,590	1,611	1,313	298	89	1,521	(11,068)	
2009	8,650	2,897	2,100	798	239	2,658	(5,992)	
2010	6,450	3,318	2,686	632	190	3,128	(3,322)	
2011	nd	3,538	2,686	852	256	3,283	3,283	
2012	nd	2,896	2,686	210	63	2,833	2,833	
2013	nd	2,227	2,686	(459)	-	2,227	2,226	
2014	nd	1,528	2,686	(1,157)	-	1,528	1,528	
2015	nd	800	2,686	(1,886)	-	800	800	
2016	nd	40	2,686	(2,645)	-	40	40	
IRR								-16.0%
NPV – WACC							14.5%	
NPV - GOVT BONDS							8.0%	

The alternative 3 has an IRR negative which is lower than the WACC (14.5%) and the government bonds (8%). The investment analysis corroborates that this scenario will not be implemented without the CDM incentive and that the scenario 1, which is the continuation of using fossil fuel would be the most likely scenario, therefore the baseline.

Sensitivity analysis

- Depreciation : 11 Years (2006 to 2016)
- Coal Price – same projection for period 2007 - 2010, and increase as per average of coal price fluctuation in 2007 - 2011 afterwards, i.e., increase by 0.8% and decrease by 0.1% per year for Narogong and Cilacap Plant Site, respectively.
- Biomass Price (average) – same projection

Summary of IRR

Year	Investment (US\$K)	Incremental cash flow (US\$K)	Depreciation	Taxable income	Tax	Net benefit	Cash flow without CERs	
2006	465	-	42	(42)	-	-	(465)	
2007	1,390	1,013	169	844	253	760	(630)	
2008	12,590	1,611	1,313	298	89	1,521	(11,068)	
2009	8,650	2,897	2,100	798	239	2,658	(5,992)	
2010	6,450	3,318	2,686	632	190	3,128	(3,322)	
2011	nd	3,619	2,686	933	280	3,339	3,339	
2012	nd	3,058	2,686	373	112	2,947	2,947	
2013	nd	2,471	2,686	(214)	-	2,471	2,471	
2014	nd	1,856	2,686	(830)	-	1,856	1,856	
2015	nd	1,211	2,686	(1,474)	-	1,211	1,211	
2016	nd	536	2,686	(2,150)	-	536	536	
IRR								-12.1%
NPV – WACC							14.5%	
NPV - GOVT BONDS							8.0%	



The sensitivity analysis confirms that the proposed activity will most likely not be implemented without the CDM incentive.

Step 3. Barrier analysis

Alternative 1 is the most probable scenario for the following reasons: it is the prevailing practice, it is technically the most feasible scenario and it does not seek additional investment.

Alternative 3 is the project activity. It is not a plausible scenario without the CDM incentives as there are major investment barriers, production losses and technical barriers. The barriers associated with the use of the alternative fuels proposed in the project activity are enumerated below.

Step 3a. Identify barriers that would prevent the implementation of the type of the proposed project activity

There are also significant barriers associated with the use of alternative fuels in cement manufacturing. There is no well established practice and therefore the implementation of the proposed project means that various barriers have to be overcome.

Investment barriers - Cost in production losses and maintenance

Besides the fact that the project is having a WACC lower than the usual level, the project activity generates indirect costs due to the clinker production losses, the increase of downtime and the increase of maintenance cost.

Technological barriers

The use of alternative fuels at the level proposed by the project activity is not the common practice and, therefore, there is no well-established technology.

Many technical barriers are to be met, mainly:

- Set-up functional infrastructure for storage and feeding
- Build the know how to operate alternative fuels installations
- Optimize raw material composition to meet the clinker standards quality

Barriers due to prevailing practice

The use of significant amount of alternative fuels for pyro-processing is not the current practice in Indonesia. Fossil fuels are the preferred choice and therefore are the current practice of the industry.

The project activity faces major barriers and risks which would prevent HIL to implement the project activity without the CDM incentives.

Sub-step 3b. Show that the identified barriers would not prevent the implementation of at least one of the alternatives (except the proposed project activity)

In the case of alternative 1 (i.e., utilization of fossil fuels), it would not face the barriers associated with the proposed project activity. This is because, aside from it being the prevailing practice, there are no specific investment barriers, production losses and technological barriers. The table above evaluates all alternatives and shows that alternative 1 is the most probable scenario.

Step 4 Common practice analysis

***Sub-step 4a. Analyze other activities similar to the proposed project activity***

The use of significant amounts of alternative fuels is not the common practice in the manufacturing industries in the Indonesia. Based on information from the World Bank publication, the use of coal is the major source of thermal energy in the local industry. The only similar project in Indonesia has been feasible with the CDM incentives.

Sub-step 4b. Discuss any similar options that are occurring

With the major barriers (investment, production losses, technological issues and prevailing practice standards) and lack of incentives the proposed project activity or similar projects are not likely to happen without the Clean Development Mechanism incentives.

Impact of CDM Registration

The CDM allows HIL to overcome the barriers related to the substitution of fossil fuels with alternative fuels.

CDM status provides many key benefits to HIL

- Prospect of CDM revenue, increase the IRR and decrease of the financial risk
- Significant reduction of the GHG emissions
- CDM revenue will encourage HIL to come up with new idea and projects reducing GHG emissions
- Gain of experience in CDM projects and build local capacity

The cement industry is aware of the emissions associated to cement production and the CDM should give real incentives to reduce these. The four above factors allow and will continue to allow HIL to dedicate financial and technical efforts as well as resources locally and at a group level to overcome the barriers.

B.6. Emission reductions:**B.6.1. Explanation of methodological choices:**

>>

Details of the calculation choices are shown in the section B.6.2 “Data and parameters available at validation” and section B.7.1 “Data and parameters monitored”.

Below are the main methodological choices:

- Used/waste fuels are part of the baseline and the related heat input and emissions are computed within the fossil fuel calculation.
- The emissions related to the little use of crude palm oil are calculated in the emissions from the use of alternative fuels and therefore the emission savings are taken out of the global emission reductions calculation.
- Emissions saving from reduction of on site transport of fossil fuels are not taken into account.
- Leakage due to reduced transport of fossil fuel is not taken into account.

B.6.2. Data and parameters that are available at validation:

All data used to calculate the baseline and estimate of the project activity emissions reduction are available. The baseline data are presented in this section. The project activity data (estimation) are part of the monitoring data and presented in section B.7.



The data and parameter stem from the annual technical report (ATR), a report that every plant within the Holcim group has to fulfil and send to the local head office and to the corporate.

Since the values applied are not always the same for the 3 kilns, the abbreviation (CC2, NR3, NR4) of each plant is given when necessary.

Data / Parameter:	C_{BI}
Data unit:	Tonne
Description:	Annual production of clinker
Source of data used:	Annual technical report
Value applied:	see calculation data base
Justification of the choice of data or description of measurement methods and procedures actually applied :	Quantity of clinker produced. Daily production monitoring using weight totalizer of the kiln feed computed with the clinker factor which is obtained by drop test. Cross- check with automatic weight system of the cement grinding input and clinker sold. ISO 9000.
Any comment:	None

Data / Parameter:	Q_{FF,BA coal}
Data unit:	Tonne
Description:	Quantity of fossil fuel (coal) used in the baseline
Source of data used:	Annual technical report
Value applied:	CC2: 299,620 NR3: 169,150 NR4: 302,246
Justification of the choice of data or description of measurement methods and procedures actually applied :	The amount of each fossil fuel is automatically daily weighted with the weight totalizer of the bin and cross-checked with the delivery and inventory. ISO 9000.
Any comment:	None

Data / Parameter:	Q_{FF,BA light oil}
Data unit:	Tonne
Description:	Quantity of fossil fuel (light oil/diesel) used in the baseline
Source of data used:	Annual technical report
Value applied:	CC2: 3,182 NR3: 2,607 NR4: 2,607
Justification of the choice of data or description of measurement methods and procedures actually applied :	Flow meters reading in continue and cross check with the delivery and inventory. ISO 9000.
Any comment:	None

Data / Parameter:	Q_{FF,BA waste oil}
--------------------------	------------------------------------



Data unit:	Tonne
Description:	Quantity of fossil fuel (waste oil/used oil) used in the baseline
Source of data used:	Annual technical report
Value applied:	CC2: 0 NR3: 7,020 NR4: 0
Justification of the choice of data or description of measurement methods and procedures actually applied :	Flow meters reading in continue and cross check with the delivery and inventory. ISO 9000.
Any comment:	None

Data / Parameter:	HV_{FF coal}
Data unit:	TJ/tonne
Description:	Lower heating value of fossil fuel (coal) used in the baseline
Source of data used:	Annual technical report
Value applied:	CC2: 0.022 NR3:0.023 NR4: 0.022
Justification of the choice of data or description of measurement methods and procedures actually applied :	Laboratory analyses cross-check with supplier and third party laboratory. A weighted average is computed. ISO 9000.
Any comment:	None

Data / Parameter:	HV_{FF light oil}
Data unit:	TJ/tonne
Description:	Lower heating value of fossil fuel (light oil/diesel) used in the baseline
Source of data used:	Annual technical report
Value applied:	CC2: 0.045 NR3:0.045 Nr4: 0.045
Justification of the choice of data or description of measurement methods and procedures actually applied :	Supplier laboratory analysis.
Any comment:	None

Data / Parameter:	HV_{FF waste oil}
Data unit:	TJ/tonne
Description:	Lower heating value of fossil fuel (waste oil/used oil) used in the baseline
Source of data used:	Annual technical report
Value applied:	CC2: - NR3:0.020 NR4: -
Justification of the choice of data or description of measurement methods	Supplier laboratory analyses cross-check with third party laboratory.



and procedures actually applied :	
Any comment:	None

Data / Parameter:	EE_{FF}
Data unit:	tCO ₂ /TJ
Description:	Weighted average annual CO ₂ emission factor for the fossil fuel that would have been consumed in the baseline
Source of data used:	Annual technical report
Value applied:	CC2: 95.63 NR3: 94.68 NR4: 94.77
Justification of the choice of data or description of measurement methods and procedures actually applied :	Specific CO ₂ emission factor from each fossil fuels come from IPCC value (2006). The weighted average is computed. ISO 9000.
Any comment:	None

Data / Parameter:	HC_{FF}
Data unit:	TJ/tClinker
Description:	Specific fuel consumption in the baseline
Source of data used:	Annual technical report
Value applied:	CC2: 0.00323 NR3: 0.00329 NR4: 0.00320
Justification of the choice of data or description of measurement methods and procedures actually applied :	This value is computed. The amount of each fossil fuel is automatically weighted and cross-checked with the amount bought. The lower heating value is fixed by laboratory analysis. ISO 9000.
Any comment:	None



waste										
HV _{AF_sorted}	nd	nd	nd	nd	nd	nd	nd	nd	nd	nd
waste										
Q _{AF_CPO}	698	731	739	739	745	745	745	745	745	745
HV _{AF_CPO}	0.0388	0.0388	0.0388	0.0388	0.0388	0.0388	0.0388	0.0388	0.0388	0.0388
HI _{AF}	45	340	777	987	1,451	1,451	1,451	1,451	1,451	1,451

NR4	2007	2008	2009	2010	2011	2012	2013	2014	2015	2016
Q _{AF_biomass} (PKS)	7,848	15,696	23,544	38,575	95,490	95,490	95,490	95,490	95,490	95,490
HV _{AF_biomass} (PKS)	0.0180	0.0180	0.0180	0.0180	0.0180	0.0180	0.0180	0.0180	0.0180	0.0180
Q _{AF_biomass} (rice husk)	23,582	23,582	23,844	77,275	80,930	80,930	80,930	80,930	80,930	80,930
HV _{AF_biomass} (rice husk)	0.0124	0.0124	0.0124	0.0124	0.0124	0.0124	0.0124	0.0124	0.0124	0.0124
Q _{AF_biomass} (SD)	0	7,848	7,848	7,715	14,691	14,691	14,691	14,691	14,691	14,691
HV _{AF_biomass} (SD)	0.0098	0.0098	0.0098	0.0098	0.0098	0.0098	0.0098	0.0098	0.0098	0.0098
Q _{AF_sorted} waste	nd	nd	nd	nd	nd	nd	nd	nd	nd	nd
HV _{AF_sorted} waste	nd	nd	nd	nd	nd	nd	nd	nd	nd	nd
Q _{AF_CPO}	1,250	1,254	1,266	1,267	1,277	1,277	1,277	1,277	1,277	1,277
HV _{AF_CPO}	0.0388	0.0388	0.0388	0.0388	0.0388	0.0388	0.0388	0.0388	0.0388	0.0388
HI _{AF}	482	700	846	1,777	2,916	2,916	2,916	2,916	2,916	2,916

Step 2. Estimation of the project specific moisture “penalty”

$$MP_y = C_{Pr,y} \times (HC_{AF} - HC_{FF})$$

Where:

MP_y = moisture penalty (TJ/yr) for year y

C_{Pr,y} = is the clinker production for year y

HC_{AF} = is the specific fuel consumption on project case (TJ/tClinker) in year y

HC_{FF} = is the specific fuel consumption in the baseline when only fossil fuel is used, in TJ/tClinker.

CC2	2007	2008	2009	2010	2011	2012	2013	2014	2015	2016
MP _v	90	124	195	238	288	268	288	288	288	288
HC _{AF}	0.00327	0.00328	0.00331	0.00332	0.00334	0.00334	0.00334	0.00334	0.00334	0.00334
HC _{FF}	0.00323									

NR3	2007	2008	2009	2010	2011	2012	2013	2014	2015	2016
MP _v	0	31	69	81	119	119	119	119	119	119
HC _{AF}	0.00329	0.00331	0.00331	0.00334	0.00335	0.00337	0.00337	0.00337	0.00337	0.00337
HC _{FF}	0.00329									



NR4	2007	2008	2009	2010	2011	2012	2013	2014	2015	2016
MP _V	47	71	126	155	222	222	222	222	222	222
HC _{AF}	0.00321	0.00322	0.00325	0.00326	0.00328	0.00328	0.00328	0.00328	0.00328	0.00328
HC _{FF}	0.00320									

Step 3 GHG emissions from the use of alternative fuels in kilns:

$$AF_{GHG} = \Sigma(Q_{AF} * HV_{AF} * EF_{AF})$$

Where:

AF_{GHG} = GHG emissions from alternative fuels (tCO₂e/yr)

Q_{AF} = monitored alternative fuels input in clinker production (tonnes/yr).

HV_{AF} = heating value(s) of the alternative fuel(s) used (TJ/tonne fuel).

EF_{AF} = emission factor(s) of alternative fuel(s) used (tCO₂e/TJ).

CO₂ emissions from burning PKS, rice husk and saw dust are CO₂-neutral. CO₂ emissions from burning CPO are calculated.

CC2	2007	2008	2009	2010	2011	2012	2013	2014	2015	2016
EF _{FF}	79.60	79.60	79.60	79.60	79.60	79.60	79.60	79.60	79.60	79.60
AF _{GHG}	3,613	3,758	3,792	3,939	3,963	3,963	3,963	3,963	3,963	3,963

NR3	2007	2008	2009	2010	2011	2012	2013	2014	2015	2016
EF _{FF}	79.60	79.60	79.60	79.60	79.60	79.60	79.60	79.60	79.60	79.60
AF _{GHG}	2,154	2,258	2,282	2,282	2,299	2,299	2,299	2,299	2,299	2,299

NR4	2007	2008	2009	2010	2011	2012	2013	2014	2015	2016
EF _{FF}	79.60	79.60	79.60	79.60	79.60	79.60	79.60	79.60	79.60	79.60
AF _{GHG}	3,860	3,872	3,910	3,912	3,944	3,944	3,944	3,944	3,944	3,944

Step 4 Baseline GHG emissions from the fossil fuel(s) displaced by the alternative fuel(s)

$$FF_{GHG} = [(Q_{AF} \times HV_{AF}) - MP_{total}] \times EF_{FF}$$

Where:

FF_{GHG} = GHG emissions from fossil fuels displaced by the alternatives (tCO₂/yr)

Q_{AF} × HV_{AF} = total actual heat provided by all alternative fuels (TJ/yr)

MP_{total} = total moisture penalty (TJ/yr)

EF_{FF} = emissions factor(s) for fossil fuel(s) displaced (tCO₂/TJ).

EF_{FF} is the estimated baseline value and would be the lowest of the following CO₂ emission factors:

- the weighted average annual CO₂ emission factor for the fossil fuel(s) consumed and monitored ex ante during the year before the validation,



- the weighted average annual CO₂ emission factor for the fossil fuel(s) consumed and monitored during the corresponding verification period (e.g. the period during which the emission reductions to be certified have been achieved),
- the weighted average annual CO₂ emission factor for the fossil fuel(s) that would have been consumed according to the baseline scenario determined in section 1 and 2 of the “Additionality and baseline scenario selection”.

For the estimation of the present calculation, the weighted average annual CO₂ emission factor for the fossil fuels consumed according to the baseline scenario.

CC2	2007	2008	2009	2010	2011	2012	2013	2014	2015	2016
EF _{FF}	95.63	95.63	95.63	95.63	95.63	95.63	95.63	95.63	95.63	95.63
FF _{GHG}	66,989	84,241	142,708	193,928	249,939	249,939	249,939	249,939	249,939	249,939

NR3	2007	2008	2009	2010	2011	2012	2013	2014	2015	2016
EF _{FF}	94.68	94.68	94.68	94.68	94.68	94.68	94.68	94.68	94.68	94.68
FF _{GHG}	4,276	29,232	67,030	85,722	126,088	126,088	126,088	126,088	126,088	126,088

NR4	2007	2008	2009	2010	2011	2012	2013	2014	2015	2016
EF _{FF}	94.77	94.77	94.77	94.77	94.77	94.77	94.77	94.77	94.77	94.77
FF _{GHG}	41,229	59,625	68,226	153,750	255,335	255,335	255,335	255,335	255,335	255,335

Step 5. GHG emissions due to on-site transportation and drying of alternative fuels

$$OT_{GHG} = OF_{AF} \times (VEF_{CO_2} + VEF_{CH_4} \times GWP_{CH_4}/1000 + VEF_{N_2O} \times GWP_{N_2O}/1000) + (FD \times FD_{HV} \times VEF_D) + OP_{AF} \times EF_{op}$$

Where:

OT _{GHG}	= GHG emissions from on-site transport and drying of alternative fuels (tCO ₂ e/yr)
OF _{AF}	= transportation fuel used for alternative fuels on-site during the year (t/yr),
VEF _{CO₂}	= CO ₂ emission factor for the transportation fuel (tCO ₂ /tonne),
VEF _{CH₄}	= CH ₄ emission factor for the transportation fuel (kg CH ₄ /tonne),
VEF _{N₂O}	= N ₂ O emission factor for the transportation fuel (kg N ₂ O/tonne),
GWP _{CH₄}	= global warming potential for CH ₄ (21),
GWP _{N₂O}	= global warming potential for N ₂ O (310),
FD	= fuel used for drying alternative fuels (t/yr),
FD _{HV}	= heating value of the fuel used for drying (TJ/t fuel)
VEF _D	= emission factor of the fuel used for drying (tCO ₂ /TJ)
OP _{AF}	= Power consumption to transport alternative fuel (MWh)
EF _{op}	= CO ₂ emission factor due to power generation (tCO ₂ /MWh)

The GHG emission generated by the use of conveyors to carry the alternative fuels is computed in this section. The CO₂ emission factor due to power generation (tCO₂/MWh) is based on methodology ACM002.



CC2	2007	2008	2009	2010	2011	2012	2013	2014	2015	2016
OF _{AF}	57	74	118	152	193	193	193	193	193	193
FD	0	0	0	0	0	0	0	0	0	0
OP _{AF}	2081	2081	2081	2081	2081	2081	2081	2081	2081	2081
EF _{op}	0.754	0.754	0.754	0.754	0.754	0.754	0.754	0.754	0.754	0.754
OT_{GHG}	1,752	1,805	1,947	2,057	2,186	2,186	2,186	2,186	2,186	2,186

NR3	2007	2008	2009	2010	2011	2012	2013	2014	2015	2016
OF _{AF}	1	22	53	66	95	95	95	95	95	95
FD	0	0	0	0	0	0	0	0	0	0
OP _{AF}	2081	2081	2081	2081	2081	2081	2081	2081	2081	2081
EF _{op}	0.754	0.754	0.754	0.754	0.754	0.754	0.754	0.754	0.754	0.754
OT_{GHG}	1,572	1,640	1,738	1,780	1,873	1,873	1,873	1,873	1,873	1,873

NR4	2007	2008	2009	2010	2011	2012	2013	2014	2015	2016
OF _{AF}	30	45	53	119	183	183	183	183	183	183
FD	0	0	0	0	0	0	0	0	0	0
OP _{AF}	2081	2081	2081	2081	2081	2081	2081	2081	2081	2081
EF _{op}	0.754	0.754	0.754	0.754	0.754	0.754	0.754	0.754	0.754	0.754
OT_{GHG}	1,665	1,714	1,739	1,949	2,157	2,157	2,157	2,157	2,157	2,157

Step 6. Emission savings from reduction of on-site transport of fossil fuels

$$OT_GHG_{FF} = OF_{FF} \times EF_{T\ CO_2e}$$

Where:

OT-GHG_{FF} = emissions from reduction of on-site transport of fossil fuels (tCO₂e)

OF_{FF} = fuel saving from on-site transportation of fossil fuels (t/yr)

EF_{T CO₂e} = emission factor of fuel used for transportation (tCO₂e/t fuel)

For conservativeness, the emissions savings are not computed.

Leakage

Step 1. CH₄ emissions due to biomass residues that would be burned in the absence of the project

$$BB_{CH_4} = Q_{AF-B} \times BCF \times CH_4F \times CH_4/C \times GWP_{CH_4}$$

Where:

BB_{CH₄} = GHG emissions due to burning of biomass residues used as alternative fuel (tCO₂e/yr)

Q_{AF-B} = amount of biomass residues used as alternative fuel that would have been burned in the open field in the absence of the project (t/yr)

BCF = carbon fraction of the biomass residue (tC/t biomass) estimated on rice husk laboratory analysis (0.30)

CH₄F = fraction of the carbon released as CH₄ in open air burning (expressed as a fraction) (1.33)

CH₄/C = mass conversion factor for carbon to methane (16 tCH₄/12 tC)



GWP_{CH_4} = global warming potential of methane (21).

To be conservative, we assume that 100% of the biomass available would be, without the project activity, burned in open air.

CC2	2007	2008	2009	2010	2011	2012	2013	2014	2015	2016
Q_{AF-B}	59,518	76,738	122,991	158,598	200,852	200,852	200,852	200,852	200,852	200,852
BB_{CH_4}	2,500	3,223	5,166	6,661	8,436	8,436	8,436	8,436	8,436	8,436

NR3	2007	2008	2009	2010	2011	2012	2013	2014	2015	2016
Q_{AF-B}	1,000	23,176	54,901	68,561	99,064	99,064	99,064	99,064	99,064	99,064
BB_{CH_4}	42	973	2,306	2,880	4,161	4,161	4,161	4,161	4,161	4,161

NR4	2007	2008	2009	2010	2011	2012	2013	2014	2015	2016
Q_{AF-B}	31,430	47,126	55,277	123,564	191,111	191,111	191,111	191,111	191,111	191,111
BB_{CH_4}	1,320	1,979	2,322	5,190	8,027	8,027	8,027	8,027	8,027	8,027

Step 2. Calculate the CH_4 emissions due to anaerobic decomposition of biomass residues at landfills

$$LW_{CH_4,y} = \Phi \times 16/12 \times F \times DOC_j \times MCF \times \sum \sum Q_{AF,j,x} \times DOC_j \times (1 - e^{-k_j}) \times e^{-k_j(y-x)} \times NFL \times GWP_{CH_4}$$

Where:

$LW_{CH_4,y}$ = Baseline GHG emissions due to anaerobic decomposition of biomass residues in landfills during the year y (tCO_{2e}/yr)

$Q_{AF,j,x}$ = amount of biomass residues of type j used as alternative fuel that would be landfilled in the absence of the project in the year x (t/yr)

Φ = Model correction factor (default 0.9) to correct for the model-uncertainties

F = Fraction of methane in the landfill gas

DOC_j = Per cent of degradable organic carbon (by weight) in the biomass type j

DOC_f = Fraction of DOC dissimilated to landfill gas

MCF = Methane Correction Factor (fraction)

k_j = Decay rate for the biomass residue stream type j

j = is biomass residue type distinguished into the biomass residue categories

x = year during the crediting period: x runs from the first year of the first crediting period (x=1) to the year for which emissions are calculated (x=y)

y = year for which LFG emissions are calculated

NFL = the non-flared portion of the landfill gas produced (%)

GWP_{CH_4} = Global warming potential valid for the relevant commitment period

To be conservative, we assume that 100% of the biomass available would be, without the project activity, burned in open air.

Step 3. Calculate emissions from off-site transport of alternative and fossil fuels

$$LK_{trans} = LK_{AF} - LK_{FF}$$

$$LK_{AF} = (Q_{AF}/CT_{AF}) \times D_{AF} \times EF_{CO_2e}/1000$$

**B.6.4 Summary of the ex-ante estimation of emission reductions:**

>>

Years	Estimation of project emission (tonnes of CO ₂ e)	Estimation of baseline emissions (tonnes of CO ₂ e)	Estimation of leakage (tonnes of CO ₂ e)	Estimation of overall emission reduction (tonnes of CO ₂ e)
Year A (2007)	14,617	112,494	-3,270	94,607
Year B	15,046	173,098	-4,619	153,433
Year C	15,408	277,964	-6,566	255,990
Year D	15,917	433,399	-10,257	407,225
Year E	16,423	631,362	-10,722	604,218
Year F	16,423	631,362	-10,722	604,218
Year G	16,423	631,362	-10,722	604,218
Year H	16,423	631,362	-10,722	604,218
Year I	16,423	631,362	-10,722	604,218
Year J	16,423	631,362	-10,722	604,218
Total (tonnes of CO ₂ e)	159,524	4,785,129	-89,044	4,536,561

B.7 Application of the monitoring methodology and description of the monitoring plan:**B.7.1 Data and parameters monitored:**

All data used to calculate the project activity emission reductions are available at verification. The values of data applied for each year of the crediting period are reported in the calculation data base.

The values which stem from external sources (for example values coming from IPCC) will be updated according to the source's publication. The data related to transport and geographical parameters will be updated, throughout the duration of the project activity.

HIL cement plants are accredited according to ISO 9000 and 14000 systems, therefore the uncertainty level of the data is relatively low. The quality control (QC) and quality assurance (QA) also includes cross checking data with other reports within the Holcim Group.

Most of the values applied for the purpose of calculating expected emission reductions are defined in the section B.6.3 Ex-ante calculation of emission reductions.

**Step 1****Monitoring heat input**

Data / Parameter:	Q_{AF} PKS																											
Data unit:	Tonne																											
Description:	Quantity of alternative fuel (PKS)																											
Source of data to be used:	Annual technical report and project activity monitoring report																											
Value of data applied for the purpose of calculating expected emission reductions in section B.5	<table border="1"> <thead> <tr> <th>Years</th> <th>CC2</th> <th>NR3</th> <th>NR4</th> </tr> </thead> <tbody> <tr> <td>2007</td> <td>15,004</td> <td>1,000</td> <td>7,848</td> </tr> <tr> <td>2008</td> <td>15,348</td> <td>7,838</td> <td>15,696</td> </tr> <tr> <td>2009</td> <td>38,406</td> <td>15,672</td> <td>23,544</td> </tr> <tr> <td>2010</td> <td>59,494</td> <td>22,833</td> <td>38,575</td> </tr> <tr> <td>2011-2016</td> <td>81,828</td> <td>38,064</td> <td>95,490</td> </tr> </tbody> </table>				Years	CC2	NR3	NR4	2007	15,004	1,000	7,848	2008	15,348	7,838	15,696	2009	38,406	15,672	23,544	2010	59,494	22,833	38,575	2011-2016	81,828	38,064	95,490
Years	CC2	NR3	NR4																									
2007	15,004	1,000	7,848																									
2008	15,348	7,838	15,696																									
2009	38,406	15,672	23,544																									
2010	59,494	22,833	38,575																									
2011-2016	81,828	38,064	95,490																									
Description of measurement methods and procedures to be applied:	The amount of each product is weighed and cross-checked with the delivery.																											
QA/QC procedures to be applied:	ISO 9000																											
Any comment:	None																											

Data / Parameter:	Q_{AF} rice husk																											
Data unit:	Tonne																											
Description:	Quantity of alternative fuel (rice husk)																											
Source of data to be used:	Annual technical report and project activity monitoring report																											
Value of data applied for the purpose of calculating expected emission reductions in section B.5	<table border="1"> <thead> <tr> <th>Years</th> <th>CC2</th> <th>NR3</th> <th>NR4</th> </tr> </thead> <tbody> <tr> <td>2007</td> <td>15,004</td> <td>0</td> <td>23,582</td> </tr> <tr> <td>2008</td> <td>30,695</td> <td>7,851</td> <td>23,582</td> </tr> <tr> <td>2009</td> <td>46,088</td> <td>31,394</td> <td>23,884</td> </tr> <tr> <td>2010</td> <td>66,931</td> <td>38,116</td> <td>77,275</td> </tr> <tr> <td>2011-2016</td> <td>81,829</td> <td>53,376</td> <td>80,930</td> </tr> </tbody> </table>				Years	CC2	NR3	NR4	2007	15,004	0	23,582	2008	30,695	7,851	23,582	2009	46,088	31,394	23,884	2010	66,931	38,116	77,275	2011-2016	81,829	53,376	80,930
Years	CC2	NR3	NR4																									
2007	15,004	0	23,582																									
2008	30,695	7,851	23,582																									
2009	46,088	31,394	23,884																									
2010	66,931	38,116	77,275																									
2011-2016	81,829	53,376	80,930																									
Description of measurement methods and procedures to be applied:	The amount of each product is weighed and cross-checked with the delivery.																											
QA/QC procedures to be applied:	ISO 9000																											
Any comment:	None																											

Data / Parameter:	Q_{AF} saw dust
--------------------------	--------------------------------



Data unit:	Tonne																								
Description:	Quantity of alternative fuel (saw dust)																								
Source of data to be used:	Annual technical report and project activity monitoring report																								
Value of data applied for the purpose of calculating expected emission reductions in section B.5	<table border="1"> <thead> <tr> <th>Years</th> <th>CC2</th> <th>NR3</th> <th>NR4</th> </tr> </thead> <tbody> <tr> <td>2007</td> <td>29,510</td> <td>0</td> <td>0</td> </tr> <tr> <td>2008</td> <td>30,695</td> <td>7,486</td> <td>7,848</td> </tr> <tr> <td>2009</td> <td>38,497</td> <td>7,836</td> <td>7,848</td> </tr> <tr> <td>2010</td> <td>32,173</td> <td>7,611</td> <td>7,715</td> </tr> <tr> <td>2011-2016</td> <td>37,195</td> <td>7,625</td> <td>14,691</td> </tr> </tbody> </table>	Years	CC2	NR3	NR4	2007	29,510	0	0	2008	30,695	7,486	7,848	2009	38,497	7,836	7,848	2010	32,173	7,611	7,715	2011-2016	37,195	7,625	14,691
Years	CC2	NR3	NR4																						
2007	29,510	0	0																						
2008	30,695	7,486	7,848																						
2009	38,497	7,836	7,848																						
2010	32,173	7,611	7,715																						
2011-2016	37,195	7,625	14,691																						
Description of measurement methods and procedures to be applied:	The amount of each product is weighed and cross-checked with the delivery.																								
QA/QC procedures to be applied:	ISO 9000																								
Any comment:	None																								

Data / Parameter:	Q_{AF} sorted waste
Data unit:	Tonne
Description:	Quantity of alternative fuel (sorted waste)
Source of data to be used:	Annual technical report and project activity monitoring report
Value of data applied for the purpose of calculating expected emission reductions in section B.5	not defined
Description of measurement methods and procedures to be applied:	The amount of each product is weighed and cross-checked with the delivery.
QA/QC procedures to be applied:	ISO 9000
Any comment:	None

Data / Parameter:	Q_{AF} CPO												
Data unit:	Tonne												
Description:	Quantity of alternative fuel (CPO)												
Source of data to be used:	Annual technical report and project activity monitoring report												
Value of data applied for the purpose of calculating expected emission reductions in	<table border="1"> <thead> <tr> <th>Years</th> <th>CC2</th> <th>NR3</th> <th>NR4</th> </tr> </thead> <tbody> <tr> <td>2007</td> <td>1,170</td> <td>698</td> <td>1,250</td> </tr> <tr> <td>2008</td> <td>1,217</td> <td>731</td> <td>1,254</td> </tr> </tbody> </table>	Years	CC2	NR3	NR4	2007	1,170	698	1,250	2008	1,217	731	1,254
Years	CC2	NR3	NR4										
2007	1,170	698	1,250										
2008	1,217	731	1,254										



section B.5	2009	1,228	739	1,266
	2010	1,275	739	1,267
	2011-2016	1,283	745	1,277
Description of measurement methods and procedures to be applied:	The amount of each product is weighed and cross-checked with the delivery.			
QA/QC procedures to be applied:	ISO 9000			
Any comment:	None			

Data / Parameter:	HV_{AF} PKS
Data unit:	TJ/tonne fuel
Description:	Lower heating value of the alternative fuels (PKS)
Source of data to be used:	Annual technical report and project activity monitoring report
Value of data applied for the purpose of calculating expected emission reductions in section B.5	0.0180
Description of measurement methods and procedures to be applied:	The lower heating value is fixed by laboratory analysis with a calorimeter cross check with a third party.
QA/QC procedures to be applied:	ISO 9000
Any comment:	None

Data / Parameter:	HV_{AF} rice husk
Data unit:	TJ/tonne fuel
Description:	Lower heating value of the alternative fuels (rice husk)
Source of data to be used:	Annual technical report and project activity monitoring report
Value of data applied for the purpose of calculating expected emission reductions in section B.5	0.0124
Description of measurement methods and procedures to be applied:	The lower heating value is fixed by laboratory analysis with a calorimeter cross check with a third party.
QA/QC procedures to be applied:	ISO 9000
Any comment:	None



Data / Parameter:	HV_{AF} saw dust
Data unit:	TJ/tonne fuel
Description:	Lower heating value of the alternative fuels (saw dust)
Source of data to be used:	Annual technical report and project activity monitoring report
Value of data applied for the purpose of calculating expected emission reductions in section B.5	0.0098
Description of measurement methods and procedures to be applied:	The lower heating value is fixed by laboratory analysis with a calorimeter cross check with a third party.
QA/QC procedures to be applied:	ISO 9000
Any comment:	None

Data / Parameter:	HV_{AF} sorted waste
Data unit:	TJ/tonne fuel
Description:	Lower heating value of the alternative fuels (sorted waste)
Source of data to be used:	Annual technical report and project activity monitoring report
Value of data applied for the purpose of calculating expected emission reductions in section B.5	not defined
Description of measurement methods and procedures to be applied:	The lower heating value will be fixed by laboratory analysis with a calorimeter cross check with a third party. Batch analysis will be conducted.
QA/QC procedures to be applied:	ISO 9000
Any comment:	None

Data / Parameter:	HV_{AF} CPO
Data unit:	TJ/tonne fuel
Description:	Lower heating value of the alternative fuels (CPO)
Source of data to be used:	Annual technical report and project activity monitoring report
Value of data applied for the purpose of calculating expected emission reductions in section B.5	0.0388



Description of measurement methods and procedures to be applied:	The lower heating value is fixed by laboratory analysis with a calorimeter.
QA/QC procedures to be applied:	ISO 9000
Any comment:	None

Data / Parameter:	HI_{AF}																											
Data unit:	TJ/y																											
Description:	Heat input from alternative fuels																											
Source of data to be used:	Annual technical report and project activity monitoring report																											
Value of data applied for the purpose of calculating expected emission reductions in section B.5	<table border="1"> <thead> <tr> <th>Years</th> <th>CC2</th> <th>NR3</th> <th>NR4</th> </tr> </thead> <tbody> <tr> <td>2007</td> <td>791</td> <td>45</td> <td>482</td> </tr> <tr> <td>2008</td> <td>1,005</td> <td>340</td> <td>700</td> </tr> <tr> <td>2009</td> <td>1,688</td> <td>777</td> <td>846</td> </tr> <tr> <td>2010</td> <td>2,266</td> <td>988</td> <td>1,777</td> </tr> <tr> <td>2011-2016</td> <td>2,902</td> <td>1,451</td> <td>2,916</td> </tr> </tbody> </table>				Years	CC2	NR3	NR4	2007	791	45	482	2008	1,005	340	700	2009	1,688	777	846	2010	2,266	988	1,777	2011-2016	2,902	1,451	2,916
Years	CC2	NR3	NR4																									
2007	791	45	482																									
2008	1,005	340	700																									
2009	1,688	777	846																									
2010	2,266	988	1,777																									
2011-2016	2,902	1,451	2,916																									
Description of measurement methods and procedures to be applied:	Compute																											
QA/QC procedures to be applied:	ISO 9000																											
Any comment:	none																											

Data / Parameter:	Q_{FF, coal}																											
Data unit:	Tonne																											
Description:	Quantity of fossil fuel (coal) used in the project activity																											
Source of data to be used:	Annual technical report and project activity monitoring report																											
Value of data applied for the purpose of calculating expected emission reductions in section B.5	<table border="1"> <thead> <tr> <th>Years</th> <th>CC2</th> <th>NR3</th> <th>NR4</th> </tr> </thead> <tbody> <tr> <td>2007</td> <td>303,444</td> <td>183,769</td> <td>332,297</td> </tr> <tr> <td>2008</td> <td>307,258</td> <td>179,985</td> <td>323,635</td> </tr> <tr> <td>2009</td> <td>279,127</td> <td>162,922</td> <td>320,628</td> </tr> <tr> <td>2010</td> <td>266,407</td> <td>153,582</td> <td>279,347</td> </tr> <tr> <td>2011-2016</td> <td>239,475</td> <td>134,766</td> <td>231,565</td> </tr> </tbody> </table>				Years	CC2	NR3	NR4	2007	303,444	183,769	332,297	2008	307,258	179,985	323,635	2009	279,127	162,922	320,628	2010	266,407	153,582	279,347	2011-2016	239,475	134,766	231,565
Years	CC2	NR3	NR4																									
2007	303,444	183,769	332,297																									
2008	307,258	179,985	323,635																									
2009	279,127	162,922	320,628																									
2010	266,407	153,582	279,347																									
2011-2016	239,475	134,766	231,565																									
Description of measurement methods and procedures to be applied:	The amount of each fossil fuel is automatically daily weighed with the weight totalizer of the bin and cross-checked with the delivery and inventory.																											
QA/QC procedures to	ISO 9000																											



be applied:	
Any comment:	none

Data / Parameter:	Q_{FF, light oil}			
Data unit:	Tonne			
Description:	Quantity of fossil fuel (light oil/diesel) used in the project activity			
Source of data to be used:	Annual technical report and project activity monitoring report			
Value of data applied for the purpose of calculating expected emission reductions in section B.5	Years	CC2	NR3	NR4
	2007	3,608	2,863	3,051
	2008	3,753	3,001	3,060
	2009	3,787	3,034	3,090
	2010	3,934	3,032	3,092
	2011-2016	3,958	3,056	3,117
Description of measurement methods and procedures to be applied:	Flow meters reading and cross check with the delivery and inventory.			
QA/QC procedures to be applied:	ISO 9000			
Any comment:	none			

Data / Parameter:	Q_{FF, waste oil}			
Data unit:	Tonne			
Description:	Quantity of fossil fuel (waste oil) used in the project activity			
Source of data to be used:	Annual technical report and project activity monitoring report			
Value of data applied for the purpose of calculating expected emission reductions in section B.5	Years	CC2	NR3	NR4
	2007	0	7,743	0
	2008	0	7,801	0
	2009	0	7,886	0
	2010	0	7,919	0
	2011-2016	0	7,945	0
Description of measurement methods and procedures to be applied:	Flow meters reading and cross-check with the delivery and inventory.			
QA/QC procedures to be applied:	ISO 9000			
Any comment:	none			

Data / Parameter:	HV_{FF coal}
Data unit:	TJ/tonne



Description:	Lower heating value of fossil fuel (coal) used in the project activity											
Source of data to be used:	Annual technical report and project activity monitoring report											
Value of data applied for the purpose of calculating expected emission reductions in section B.5	<table border="1"> <thead> <tr> <th>Years</th> <th>CC2</th> <th>NR3</th> <th>NR4</th> </tr> </thead> <tbody> <tr> <td>2007</td> <td>0.022</td> <td>0.023</td> <td>0.022</td> </tr> </tbody> </table>				Years	CC2	NR3	NR4	2007	0.022	0.023	0.022
Years	CC2	NR3	NR4									
2007	0.022	0.023	0.022									
Description of measurement methods and procedures to be applied:	Laboratory analysis cross-check with supplier and third party laboratory. A weighted average is computed.											
QA/QC procedures to be applied:	ISO 9000											
Any comment:	none											

Data / Parameter:	HV_{FF} light oil			
Data unit:	TJ/tonne			
Description:	Lower heating value of fossil fuel (light oil/diesel) used in the project activity			
Source of data to be used:	Annual technical report and project activity monitoring report			
Value of data applied for the purpose of calculating expected emission reductions in section B.5	0.045			
Description of measurement methods and procedures to be applied:	Supplier laboratory analysis.			
QA/QC procedures to be applied:	ISO 9000			
Any comment:	none			

Data / Parameter:	HV_{FF} waste oil			
Data unit:	TJ/tonne			
Description:	Lower heating value of fossil fuel (waste oil) used in the project activity			
Source of data to be used:	Annual technical report and project activity monitoring report			
Value of data applied for the purpose of calculating expected emission reductions in section B.5	0.020			
Description of measurement methods and procedures to be applied:	Supplier laboratory analysis cross-check with third party laboratory.			



applied:	
QA/QC procedures to be applied:	ISO 9000
Any comment:	none

Step 2**Monitoring project specific moisture penalty**

Data / Parameter:	C_{Pr,y}
Data unit:	tonne
Description:	Annual clinker production
Source of data to be used:	Annual technical report and project activity monitoring report
Value of data applied for the purpose of calculating expected emission reductions in section B.5	see calculation data base
Description of measurement methods and procedures to be applied:	Quantity of clinker produced. Weighted and cross-checked with the clinker content and merchandise sold.
QA/QC procedures to be applied:	ISO 9000
Any comment:	none

Data / Parameter:	MP_y																								
Data unit:	TJ/y																								
Description:	Moisture penalty for year y																								
Source of data to be used:	Annual technical report and project activity monitoring report																								
Value of data applied for the purpose of calculating expected emission reductions in section B.5	<table border="1"> <thead> <tr> <th>Years</th> <th>CC2</th> <th>NR3</th> <th>NR4</th> </tr> </thead> <tbody> <tr> <td>2007</td> <td>90</td> <td>0</td> <td>47</td> </tr> <tr> <td>2008</td> <td>124</td> <td>31</td> <td>71</td> </tr> <tr> <td>2009</td> <td>195</td> <td>69</td> <td>126</td> </tr> <tr> <td>2010</td> <td>238</td> <td>82</td> <td>155</td> </tr> <tr> <td>2011-2016</td> <td>288</td> <td>119</td> <td>222</td> </tr> </tbody> </table>	Years	CC2	NR3	NR4	2007	90	0	47	2008	124	31	71	2009	195	69	126	2010	238	82	155	2011-2016	288	119	222
Years	CC2	NR3	NR4																						
2007	90	0	47																						
2008	124	31	71																						
2009	195	69	126																						
2010	238	82	155																						
2011-2016	288	119	222																						
Description of measurement methods and procedures to be applied:	Compute																								
QA/QC procedures to be applied:	ISO 9000																								
Any comment:	None																								



Data / Parameter:	HC_{AF,y}			
Data unit:	TJ/t clinker			
Description:	Specific fuel consumption in project case in year y			
Source of data to be used:	Annual technical report and project activity monitoring report			
Value of data applied for the purpose of calculating expected emission reductions in section B.5	Years	CC2	NR3	NR4
	2007	0.00327	0.00329	0.00321
	2008	0.00328	0.00331	0.00322
	2009	0.00331	0.00334	0.00325
	2010	0.00332	0.00335	0.00326
	2011-2016	0.00334	0.00337	0.00328
Description of measurement methods and procedures to be applied:	Compute			
QA/QC procedures to be applied:	ISO 9000			
Any comment:	None			

Step 3**Monitoring GHG emissions from the use of alternative fuels in kilns**

Data / Parameter:	EF_{AF}
Data unit:	tCO ₂ e/TJ
Description:	Emission factor of alternative fuel used
Source of data to be used:	IPCC 2006
Value of data applied for the purpose of calculating expected emission reductions in section B.5	79.60
Description of measurement methods and procedures to be applied:	IPCC and weight average computation
QA/QC procedures to be applied:	ISO 9000
Any comment:	GHG emissions from CPO are calculated in the proposed project activity. Waste oil is calculated with the fossil fuel emissions.

Data / Parameter:	AF_{GHG}
Data unit:	tCO ₂ e/y
Description:	GHG emissions from alternative fuels



Source of data to be used:	Annual technical report and project activity monitoring report																											
Value of data applied for the purpose of calculating expected emission reductions in section B.5	<table border="1"> <thead> <tr> <th>Years</th> <th>CC2</th> <th>NR3</th> <th>NR4</th> </tr> </thead> <tbody> <tr> <td>2007</td> <td>3,613</td> <td>2,154</td> <td>3,860</td> </tr> <tr> <td>2008</td> <td>3,758</td> <td>2,258</td> <td>3,872</td> </tr> <tr> <td>2009</td> <td>3,792</td> <td>2,282</td> <td>3,910</td> </tr> <tr> <td>2010</td> <td>3,939</td> <td>2,282</td> <td>3,912</td> </tr> <tr> <td>2011-2016</td> <td>3,963</td> <td>2,299</td> <td>3,944</td> </tr> </tbody> </table>				Years	CC2	NR3	NR4	2007	3,613	2,154	3,860	2008	3,758	2,258	3,872	2009	3,792	2,282	3,910	2010	3,939	2,282	3,912	2011-2016	3,963	2,299	3,944
Years	CC2	NR3	NR4																									
2007	3,613	2,154	3,860																									
2008	3,758	2,258	3,872																									
2009	3,792	2,282	3,910																									
2010	3,939	2,282	3,912																									
2011-2016	3,963	2,299	3,944																									
Description of measurement methods and procedures to be applied:	Weight average computation																											
QA/QC procedures to be applied:	ISO 9000																											
Any comment:	GHG emissions from CPO are calculated in the proposed project activity. Waste oil is calculated with the fossil fuel emissions.																											

Step 4**Monitoring baseline GHG emissions from the fossil fuels displaced by the alternative fuels**

Data / Parameter:	EE_{FF,y}											
Data unit:	tCO ₂ /TJ											
Description:	Weight average annual CO ₂ emission factor for fossil fuel consumed and monitored during the corresponding verification period											
Source of data to be used:	Project activity monitoring report											
Value of data applied for the purpose of calculating expected emission reductions in section B.5	<table border="1"> <thead> <tr> <th>Years</th> <th>CC2</th> <th>NR3</th> <th>NR4</th> </tr> </thead> <tbody> <tr> <td>2007-2016</td> <td>95.63</td> <td>94.68</td> <td>94.77</td> </tr> </tbody> </table>				Years	CC2	NR3	NR4	2007-2016	95.63	94.68	94.77
Years	CC2	NR3	NR4									
2007-2016	95.63	94.68	94.77									
Description of measurement methods and procedures to be applied:	Compute											
QA/QC procedures to be applied:	ISO 9000											
Any comment:	None											

Step5**Monitoring GHG emissions due to on site transportation and drying of alternative fuels**

Data / Parameter:	Cons_{AF biomass}		
Data unit:	litre /tonnes of biomass		
Description:	Consumption of the loader used to transport fuel the biomass		



Source of data to be used:	test on site											
Value of data applied for the purpose of calculating expected emission reductions in section B.5	<table border="1"> <thead> <tr> <th>Years</th> <th>CC2</th> <th>NR3</th> <th>NR4</th> </tr> </thead> <tbody> <tr> <td>2007-2016</td> <td>0.96</td> <td>0.96</td> <td>0.96</td> </tr> </tbody> </table>				Years	CC2	NR3	NR4	2007-2016	0.96	0.96	0.96
Years	CC2	NR3	NR4									
2007-2016	0.96	0.96	0.96									
Description of measurement methods and procedures to be applied:	The amount of fuel (litre) used per month will be reported by the diesel oil station (inside the plant).											
QA/QC procedures to be applied:	ISO 9000											
Any comment:	Biomass is handled with a loader to the hopper.											

Data / Parameter:	OF_{AF}																											
Data unit:	t/y																											
Description:	Transportation fuel used for alternative fuels on site during the year																											
Source of data to be used:	Project activity monitoring report																											
Value of data applied for the purpose of calculating expected emission reductions in section B.5	<table border="1"> <thead> <tr> <th>Years</th> <th>CC2</th> <th>NR3</th> <th>NR4</th> </tr> </thead> <tbody> <tr> <td>2007</td> <td>57</td> <td>1</td> <td>30</td> </tr> <tr> <td>2008</td> <td>74</td> <td>22</td> <td>45</td> </tr> <tr> <td>2009</td> <td>118</td> <td>53</td> <td>53</td> </tr> <tr> <td>2010</td> <td>152</td> <td>66</td> <td>119</td> </tr> <tr> <td>2011-2016</td> <td>193</td> <td>95</td> <td>183</td> </tr> </tbody> </table>				Years	CC2	NR3	NR4	2007	57	1	30	2008	74	22	45	2009	118	53	53	2010	152	66	119	2011-2016	193	95	183
Years	CC2	NR3	NR4																									
2007	57	1	30																									
2008	74	22	45																									
2009	118	53	53																									
2010	152	66	119																									
2011-2016	193	95	183																									
Description of measurement methods and procedures to be applied:	The amount of fuel (litre) used per month will be reported by the fuel station (inside the plant).																											
QA/QC procedures to be applied:	ISO 9000																											
Any comment:	Biomass is handled with a loader to the hopper.																											

Data / Parameter:	OT_{GHG transportation (loader)}																							
Data unit:	tCO ₂ /y																							
Description:	GHG emissions from on site transport and drying of alternative fuels																							
Source of data to be used:	Project activity monitoring report																							
Value of data applied for the purpose of calculating expected emission reductions in section B.5	<table border="1"> <thead> <tr> <th>Years</th> <th>CC2</th> <th>NR3</th> <th>NR4</th> </tr> </thead> <tbody> <tr> <td>2007</td> <td>183</td> <td>3</td> <td>97</td> </tr> <tr> <td>2008</td> <td>236</td> <td>71</td> <td>145</td> </tr> <tr> <td>2009</td> <td>378</td> <td>169</td> <td>170</td> </tr> <tr> <td>2010</td> <td>488</td> <td>211</td> <td>380</td> </tr> </tbody> </table>				Years	CC2	NR3	NR4	2007	183	3	97	2008	236	71	145	2009	378	169	170	2010	488	211	380
Years	CC2	NR3	NR4																					
2007	183	3	97																					
2008	236	71	145																					
2009	378	169	170																					
2010	488	211	380																					



	2011-2016	618	305	588
Description of measurement methods and procedures to be applied:	Compute			
QA/QC procedures to be applied:	ISO 9000			
Any comment:	none			

Data / Parameter:	OP_{AF}			
Data unit:	MWh/y			
Description:	Electricity consumption from on site alternative fuels transportation with conveyors.			
Source of data to be used:	Project activity monitoring report			
Value of data applied for the purpose of calculating expected emission reductions in section B.5	Years	CC2	NR3	NR4
	2007-2016	2,081	2,081	2,081
Description of measurement methods and procedures to be applied:	Compute on the maximal power requirement on 95% of 8760 hours.			
QA/QC procedures to be applied:	ISO 9000			
Any comment:	None			

Data / Parameter:	EF_P			
Data unit:	tCO ₂ / MWh			
Description:	Emission factor for electricity used			
Source of data to be used:	Letter from PLN (State owned electric company) based on ACM0002			
Value of data applied for the purpose of calculating expected emission reductions in section B.5	0.754			
Description of measurement methods and procedures to be applied:	none			
QA/QC procedures to be applied:	none			
Any comment:	None			



Data / Parameter:	OT_{GHG feeding}											
Data unit:	tCO ₂ /y											
Description:	GHG emissions from on site electricity consumption for alternative fuels transportation with conveyors.											
Source of data to be used:	Project activity monitoring report											
Value of data applied for the purpose of calculating expected emission reductions in section B.5	<table border="1"> <thead> <tr> <th>Years</th> <th>CC2</th> <th>NR3</th> <th>NR4</th> </tr> </thead> <tbody> <tr> <td>2007-2016</td> <td>1,569</td> <td>1,569</td> <td>1,569</td> </tr> </tbody> </table>				Years	CC2	NR3	NR4	2007-2016	1,569	1,569	1,569
Years	CC2	NR3	NR4									
2007-2016	1,569	1,569	1,569									
Description of measurement methods and procedures to be applied:	Compute											
QA/QC procedures to be applied:	ISO 9000											
Any comment:	None											

Data / Parameter:	OT_{GHG}																											
Data unit:	tCO ₂ /y																											
Description:	GHG emissions from on site transport and drying of alternative fuels																											
Source of data to be used:	Project activity monitoring report																											
Value of data applied for the purpose of calculating expected emission reductions in section B.5	<table border="1"> <thead> <tr> <th>Years</th> <th>CC2</th> <th>NR3</th> <th>NR4</th> </tr> </thead> <tbody> <tr> <td>2007</td> <td>1,752</td> <td>1,572</td> <td>1,665</td> </tr> <tr> <td>2008</td> <td>1,805</td> <td>1,640</td> <td>1,714</td> </tr> <tr> <td>2009</td> <td>1,947</td> <td>1,738</td> <td>1,739</td> </tr> <tr> <td>2010</td> <td>2,057</td> <td>1,780</td> <td>1,949</td> </tr> <tr> <td>2011-2016</td> <td>2,186</td> <td>1,873</td> <td>2,157</td> </tr> </tbody> </table>				Years	CC2	NR3	NR4	2007	1,752	1,572	1,665	2008	1,805	1,640	1,714	2009	1,947	1,738	1,739	2010	2,057	1,780	1,949	2011-2016	2,186	1,873	2,157
Years	CC2	NR3	NR4																									
2007	1,752	1,572	1,665																									
2008	1,805	1,640	1,714																									
2009	1,947	1,738	1,739																									
2010	2,057	1,780	1,949																									
2011-2016	2,186	1,873	2,157																									
Description of measurement methods and procedures to be applied:	Compute																											
QA/QC procedures to be applied:	ISO 9000																											
Any comment:	None																											

Step 6**Monitoring emission saving from reduction of on site transport of fossil fuels**

Not computed for conservativeness.

Leakage

**Step 1****Monitoring CH₄ emissions due to biomass residues that would be burned in the absence of the project**

Data / Parameter:	Q_{AF-B}			
Data unit:	t/y			
Description:	Amount of biomass residue used as alternative fuel that would have been burned in the open field in the absence of the project.			
Source of data to be used:	Annual technical report and project activity monitoring report			
Value of data applied for the purpose of calculating expected emission reductions in section B.5	Years	CC2	NR3	NR4
	2007	59,518	1,000	31,430
	2008	76,738	23,176	47,126
	2009	122,991	54,901	55,277
	2010	158,598	68,561	123,564
	2011-2016	200,852	99,064	191,111
Description of measurement methods and procedures to be applied:	The amount of each product is weighted and cross-checked with the delivery.			
QA/QC procedures to be applied:	ISO 9000			
Any comment:	For conservativeness we assume that 100% of the biomass used in the project activity would be burned in open air without the project.			

Data / Parameter:	BCF			
Data unit:	tC/t biomass			
Description:	Carbon fraction of the biomass residue			
Source of data to be used:	IPCC			
Value of data applied for the purpose of calculating expected emission reductions in section B.5	0.30			
Description of measurement methods and procedures to be applied:	None			
QA/QC procedures to be applied:	None			
Any comment:	None			

Data / Parameter:	BB_{CH₄}			
--------------------------	------------------------------------	--	--	--



Data unit:	tCO ₂ e/y																								
Description:	GHG emissions due to burning of biomass residue that is used as alternative fuel																								
Source of data to be used:	Project activity data base																								
Value of data applied for the purpose of calculating expected emission reductions in section B.5	<table border="1"> <thead> <tr> <th>Years</th> <th>CC2</th> <th>NR3</th> <th>NR4</th> </tr> </thead> <tbody> <tr> <td>2007-2016</td> <td>2,500</td> <td>42</td> <td>1,320</td> </tr> <tr> <td>2008</td> <td>3,223</td> <td>973</td> <td>1,979</td> </tr> <tr> <td>2009</td> <td>5,166</td> <td>2,306</td> <td>2,322</td> </tr> <tr> <td>2010</td> <td>6,661</td> <td>2,880</td> <td>5,190</td> </tr> <tr> <td>2011-2016</td> <td>8,436</td> <td>4,161</td> <td>8,027</td> </tr> </tbody> </table>	Years	CC2	NR3	NR4	2007-2016	2,500	42	1,320	2008	3,223	973	1,979	2009	5,166	2,306	2,322	2010	6,661	2,880	5,190	2011-2016	8,436	4,161	8,027
Years	CC2	NR3	NR4																						
2007-2016	2,500	42	1,320																						
2008	3,223	973	1,979																						
2009	5,166	2,306	2,322																						
2010	6,661	2,880	5,190																						
2011-2016	8,436	4,161	8,027																						
Description of measurement methods and procedures to be applied:	Compute																								
QA/QC procedures to be applied:	ISO 9000																								
Any comment:	None																								

Step 2**Monitoring CH₄ emissions due to anaerobic decomposition of biomass residues at landfills**

For conservativeness, we assume that 100% of the biomass available for the project activity would be burned in open air in the absence of the project.

Step 3**Monitoring emissions from off-site transport of alternative and fossil fuels**

Data / Parameter:	CB_{AF} PKS								
Data unit:	Tonnes/barge								
Description:	Average barge capacity (PKS)								
Source of data to be used:	Transporters								
Value of data applied for the purpose of calculating expected emission reductions in section B.5	<table border="1"> <thead> <tr> <th>Years</th> <th>CC2</th> <th>NR3</th> <th>NR4</th> </tr> </thead> <tbody> <tr> <td>2007-2016</td> <td>6,000</td> <td>2,500</td> <td>2,500</td> </tr> </tbody> </table>	Years	CC2	NR3	NR4	2007-2016	6,000	2,500	2,500
Years	CC2	NR3	NR4						
2007-2016	6,000	2,500	2,500						
Description of measurement methods and procedures to be applied:	Cross-checked with transporters.								
QA/QC procedures to be applied:	ISO 9000								
Any comment:	none								



Data / Parameter:	D_{AF barge} PKS			
Data unit:	Nautical miles			
Description:	Distance port to port			
Source of data to be used:	geographical data			
Value of data applied for the purpose of calculating expected emission reductions in section B.5	Years	CC2	NR3	NR4
	2007-2016	526	226	226
Description of measurement methods and procedures to be applied:	Cross-checked with transporters.			
QA/QC procedures to be applied:	ISO 9000			
Any comment:	none			

Data / Parameter:	Cons_{AF barge} PKS			
Data unit:	tonne of fuel/nautical mile			
Description:	tonne of fuel/nautical mile			
Source of data to be used:	Transporters			
Value of data applied for the purpose of calculating expected emission reductions in section B.5	Years	CC2	NR3	NR4
	2007-2016	0.06	0.06	0.06
Description of measurement methods and procedures to be applied:	Cross-checked with transporters.			
QA/QC procedures to be applied:	ISO 9000			
Any comment:	none			

Data / Parameter:	HV_{barge}			
Data unit:	GJ/t			
Description:	Heating value of the fuel (barge)			
Source of data to be used:	IPCC			
Value of data applied for the purpose of calculating expected emission reductions in section B.5	Years	CC2	NR3	NR4
	2007-2016	42	42	42
Description of measurement methods and procedures to be applied:	---			
QA/QC procedures to be applied:	ISO 9000			



Any comment:	none
--------------	------

Data / Parameter:	EE_{barge}			
Data unit:	kgCO ₂ /GL			
Description:	Emission factor of the fuel (barge)			
Source of data to be used:	IPCC			
Value of data applied for the purpose of calculating expected emission reductions in section B.5	Years	CC2	NR3	NR4
	2007-2016	77.40	77.40	77.40
Description of measurement methods and procedures to be applied:	---			
QA/QC procedures to be applied:	ISO 9000			
Any comment:	none			

Data / Parameter:	LK_{AF PKS barge}			
Data unit:	tCO ₂ /y			
Description:	Leakage resulting from transport alternative fuels (PKS) with the barge			
Source of data to be used:	Project activity data base			
Value of data applied for the purpose of calculating expected emission reductions in section B.5	Years	CC2	NR3	NR4
	2007	265	18	143
	2008	272	143	287
	2009	680	286	430
	2010	1,053	417	705
	2011-2016	1,448	696	1,745
Description of measurement methods and procedures to be applied:	Compute			
QA/QC procedures to be applied:	ISO 9000			
Any comment:	none			

Data / Parameter:	CT_{AF PKS}			
Data unit:	Tonnes/truck			
Description:	Average truck capacity (PKS)			
Source of data to be used:	Weighting post data base and transporters			
Value of data applied				



CDM – Executive Board

for the purpose of calculating expected emission reductions in section B.5	Years	CC2	NR3	NR4
	2007-2016	-	20	20
Description of measurement methods and procedures to be applied:	Weighted and cross-checked with bills.			
QA/QC procedures to be applied:	ISO 9000			
Any comment:	none			

Data / Parameter:	CT_{AF} rice husk			
Data unit:	Tonnes/truck			
Description:	Average truck capacity (rice husk)			
Source of data to be used:	Weighting post data base and transporters			
Value of data applied for the purpose of calculating expected emission reductions in section B.5	Years	CC2	NR3	NR4
	2007-2016	3.2	3.2	3.2
Description of measurement methods and procedures to be applied:	Weighted and cross-checked with bills.			
QA/QC procedures to be applied:	ISO 9000			
Any comment:	none			

Data / Parameter:	CT_{AF} saw dust			
Data unit:	Tonnes/truck			
Description:	Average truck capacity			
Source of data to be used:	Weighting post data base and transporters			
Value of data applied for the purpose of calculating expected emission reductions in section B.5	Years	CC2	NR3	NR4
	2007-2016	4.5	4.5	4.5
Description of measurement methods and procedures to be applied:	Weighted and cross-checked with bills.			
QA/QC procedures to be applied:	ISO 9000			
Any comment:	none			



Data / Parameter:	CT_{AF} sorted waste
Data unit:	Tonnes/truck
Description:	Average truck capacity
Source of data to be used:	Weighting post data base and transporters
Value of data applied for the purpose of calculating expected emission reductions in section B.5	not define
Description of measurement methods and procedures to be applied:	Weighted and cross-checked with bills.
QA/QC procedures to be applied:	ISO 9000
Any comment:	none

Data / Parameter:	CT_{AF} CPO								
Data unit:	Tonnes/truck								
Description:	Average truck capacity								
Source of data to be used:	Weighting post data base and transporters								
Value of data applied for the purpose of calculating expected emission reductions in section B.5	<table border="1"> <thead> <tr> <th>Years</th> <th>CC2</th> <th>NR3</th> <th>NR4</th> </tr> </thead> <tbody> <tr> <td>2007-2016</td> <td>15</td> <td>15</td> <td>15</td> </tr> </tbody> </table>	Years	CC2	NR3	NR4	2007-2016	15	15	15
Years	CC2	NR3	NR4						
2007-2016	15	15	15						
Description of measurement methods and procedures to be applied:	Weighted and cross-checked with bills.								
QA/QC procedures to be applied:	ISO 9000								
Any comment:	none								

Data / Parameter:	D_{AF} PKS								
Data unit:	Km/truck								
Description:	Average round trip distance between the alternative fuel supply sites (PKS) and the cement plant sites								
Source of data to be used:	Geographical data								
Value of data applied for the purpose of calculating expected emission reductions in	<table border="1"> <thead> <tr> <th>Years</th> <th>CC2</th> <th>NR3</th> <th>NR4</th> </tr> </thead> <tbody> <tr> <td>2007-2016</td> <td>-</td> <td>90</td> <td>90</td> </tr> </tbody> </table>	Years	CC2	NR3	NR4	2007-2016	-	90	90
Years	CC2	NR3	NR4						
2007-2016	-	90	90						



section B.5	
Description of measurement methods and procedures to be applied:	Geographical data cross-checked with transporters
QA/QC procedures to be applied:	ISO 9000
Any comment:	none

Data / Parameter:	D_{AF} rice husk			
Data unit:	Km/truck			
Description:	Average round trip distance between the alternative fuel supply sites (rice husk) and the cement plant sites			
Source of data to be used:	Geographical data			
Value of data applied for the purpose of calculating expected emission reductions in section B.5	Years	CC2	NR3	NR4
	2007-2016	340	280	280
Description of measurement methods and procedures to be applied:	Geographical data cross-checked with transporters			
QA/QC procedures to be applied:	ISO 9000			
Any comment:	none			

Data / Parameter:	D_{AF} saw dust			
Data unit:	Km/truck			
Description:	Average round trip distance between the alternative fuel supply sites (saw dust) and the cement plant sites			
Source of data to be used:	Geographical data			
Value of data applied for the purpose of calculating expected emission reductions in section B.5	Years	CC2	NR3	NR4
	2007-2016	340	160	160
Description of measurement methods and procedures to be applied:	Geographical data cross-checked with transporters			
QA/QC procedures to be applied:	ISO 9000			
Any comment:	The average distance to the supply sites is used for the forecast.			



Data / Parameter:	D_{AF sorted waste}
Data unit:	Km/truck
Description:	Average round trip distance between the alternative fuel supply sites (sorted waste) and the cement plant sites
Source of data to be used:	Geographical data
Value of data applied for the purpose of calculating expected emission reductions in section B.5	Not defined
Description of measurement methods and procedures to be applied:	Geographical data cross-checked with transporters
QA/QC procedures to be applied:	ISO 9000
Any comment:	The average distance to the supply sites is used for the forecast.

Data / Parameter:	D_{AF CPO}								
Data unit:	Km/truck								
Description:	Average round trip distance between the alternative fuel supply sites (CPO) and the cement plant sites								
Source of data to be used:	Geographical data								
Value of data applied for the purpose of calculating expected emission reductions in section B.5	<table border="1"> <thead> <tr> <th>Years</th> <th>CC2</th> <th>NR3</th> <th>NR4</th> </tr> </thead> <tbody> <tr> <td>2007-2016</td> <td>600</td> <td>600</td> <td>600</td> </tr> </tbody> </table>	Years	CC2	NR3	NR4	2007-2016	600	600	600
Years	CC2	NR3	NR4						
2007-2016	600	600	600						
Description of measurement methods and procedures to be applied:	Geographical data cross-checked with transporters								
QA/QC procedures to be applied:	ISO 9000								
Any comment:	The average distance to the supply sites is used for the forecast.								

Data / Parameter:	LK_{AF truck}												
Data unit:	tCO ₂ /y												
Description:	Leakage resulting from truck transportation of all alternative fuels												
Source of data to be used:	Project activity data base												
Value of data applied for the purpose of calculating expected emission reductions in	<table border="1"> <thead> <tr> <th>Years</th> <th>CC2</th> <th>NR3</th> <th>NR4</th> </tr> </thead> <tbody> <tr> <td>2007</td> <td>4,288</td> <td>36</td> <td>2,381</td> </tr> <tr> <td>2008</td> <td>6,236</td> <td>1,127</td> <td>2,729</td> </tr> </tbody> </table>	Years	CC2	NR3	NR4	2007	4,288	36	2,381	2008	6,236	1,127	2,729
Years	CC2	NR3	NR4										
2007	4,288	36	2,381										
2008	6,236	1,127	2,729										



section B.5	2009	8,702	3,463	2,798
	2010	10,628	4,141	8,043
	2011-2016	12,802	5,697	8,957
Description of measurement methods and procedures to be applied:	Compute			
QA/QC procedures to be applied:	ISO 9000			
Any comment:	none			

Data / Parameter:	LK_{trans} (=LK_{AF})			
Data unit:	tCO ₂ /y			
Description:	Leakage resulting from transport of alternative fuels less leakage due to reduced transport of fossil fuels			
Source of data to be used:	Project activity data base			
Value of data applied for the purpose of calculating expected emission reductions in section B.5	Years	CC2	NR3	NR4
	2007	4,554	54	2,524
	2008	6,508	1,271	3,016
	2009	9,381	3,749	3,228
	2010	11,681	4,559	8,748
	2011-2016	14,250	6,393	10,702
Description of measurement methods and procedures to be applied:	Compute			
QA/QC procedures to be applied:	ISO 9000			
Any comment:	To be conservative, leakage due to reduced transport of fossil fuels is not taken into account.			

Step 4**Monitoring emissions from off site drying (or preparing) of alternatives fuels**

Data / Parameter:	Q_{AF} prepared off site
Data unit:	tonne
Description:	Quantity of alternative fuels prepared off site
Source of data to be used:	Project activity data base and suppliers data base
Value of data applied for the purpose of calculating expected emission reductions in	0



section B.5	
Description of measurement methods and procedures to be applied:	---
QA/QC procedures to be applied:	ISO 9000
Any comment:	none

Data / Parameter:	GHG_{PAFO}
Data unit:	tCO ₂ /y
Description:	GHG emissions generated during the preparation of alternative fuels outside the project
Source of data to be used:	Project activity data base
Value of data applied for the purpose of calculating expected emission reductions in section B.5	0
Description of measurement methods and procedures to be applied:	Compute
QA/QC procedures to be applied:	ISO 9000
Any comment:	none

B.7.2 Description of the monitoring plan:

>>

Most of the data is already collected in the annual technical report (ATR). To facilitate the verification a specific report (project activity data base) will be handled.

The technical director, responsible for monitoring, has assigned a responsible for the specific reporting of the project activity. The same team which is doing the overall monitoring is going to proceed to the collection and monitoring of the data. The data related to the transportation of the alternative fuels will be integrated into the report.

B.8 Date of completion of the application of the baseline study and monitoring methodology and the name of the responsible person(s)/entity(ies)

>>

27/04/2007

PT Holcim Indonesia Tbk Indonesia Ltd: Tim Mackay, Eamon Ginley, Vincent Aloysius, Oepoyo Prakoso, and CDM team.

Holcim Group: Catherine Martin-Robert, Bruno Vanderborgh.



The two entities above are the project participants. Contact information is available in Annex 1.

SECTION C. Duration of the project activity / crediting period**C.1 Duration of the project activity:****C.1.1. Starting date of the project activity:**

>>

Test and trials has been done in 2005. The project activity has started in January 2006.

C.1.2. Expected operational lifetime of the project activity:

>>

11 years

C.2 Choice of the crediting period and related information:**C.2.1. Renewable crediting period**

Not applicable for the project activity.

C.2.1.1. Starting date of the first crediting period:

>>

C.2.1.2. Length of the first crediting period:

>>

C.2.2. Fixed crediting period:**C.2.2.1. Starting date:**

>>

01/08/2007

C.2.2.2. Length:

>>

10 years

SECTION D. Environmental impacts

>>

D.1. Documentation on the analysis of the environmental impacts, including transboundary impacts:

>>



The Indonesian authorities don't require an environmental impact assessment for the proposed project activity. The project activity has negligible impact on the environment.

The environment management system of the 2 plants of HIL is ISO 14001-certified. This means that HIL has undertaken a systematic review of the key environmental impacts of their operations, have identified appropriate management and monitoring of those impacts and undertake regular management review of their environmental performance and the performance of the management system.

Additionally, HIL is subject to the Holcim Group Emissions Monitoring and Reporting Standard, which requires the installation of continuous emissions monitoring equipment for dust, SO₂, NO_x and VOC and the (at least) annual monitoring of a range of other substances. These results, along with other environmental data and information, are collated and reported annually in a standard format to Holcim Group Support in Switzerland. The results are benchmarked across the Group and regional and plant management receive feedback on their environmental performance.

D.2. If environmental impacts are considered significant by the project participants or the host Party, please provide conclusions and all references to support documentation of an environmental impact assessment undertaken in accordance with the procedures as required by the host Party:

>>

Not applicable

SECTION E. Stakeholders' comments

>>

E.1. Brief description how comments by local stakeholders have been invited and compiled:

>>

PT Holcim Indonesia Tbk has invited the local stakeholders to comment on the proposed project. Announcements in the local newspaper as well as specific meetings have been hold in Narogong and Cilacap.

The announcement was published in the newspaper Radar Bogor and Radar Banyumas on the 8 of January 2007. A contact person and numbers were given.

A letter of invitation has been sent to the stakeholders of the Cilacap's community to invite them for a dialog on December 19th 2006. About 80 persons were presents. Minutes of meeting, photos and the list of participants are available.

As well, a letter of invitation has been sent to the stakeholders of the Narogong's community to invite them for a dialog on January 31st 2007. More than 40 persons were presents. Minutes of meeting, photos and the list of participants are available.

E.2. Summary of the comments received:

>>

PT Holcim Indonesia Tbk has not received comment following the announcement in the local newspapers.



The concerns received during the stakeholders meeting in Cilacap were on the potential utilization of rice straw, on the brick's manufacturers which use a small amount of rice husk and on the possibility PT Holcim Indonesia Tbk to support a project to restore mangrove in the region.

The concerns received during the stakeholders meeting in Narogong were mainly on the procedure for the community involved to supply Holcim with biomass. A remark on the importance of a long term project for the benefit of the community to ensure that the business opportunities are durable was mentioned.

E.3. Report on how due account was taken of any comments received:

>>

Regarding the utilization of rice straw, there is a feasibility study including other alternative fuels such as rice straw which is in progress. As the rice husk generation is about 100 times higher than the amount proposed to be used by the project, the small industries will not encounter negative impact on the availability. The name of the Community relation officer was given for the query on mangrove rehabilitation. Indeed, PT Holcim Indonesia Tbk participates actively in the community by financing similar projects.

Regarding the procedure to supply Holcim with biomass, the contact name of the biomass field officer and his phone numbers were given to the participants. As the project proposed a crediting period of 10 years, the concern of a long term partnership with the community regarding the biomass supply is therefore taken into account with such a project.

**Annex 1****CONTACT INFORMATION ON PARTICIPANTS IN THE PROJECT ACTIVITY**

Organization:	PT Holcim Indonesia Tbk
Street/P.O.Box:	Jl Jenderal Gatot Subroto N°38
Building:	Menara Jamsostek, North Tower, 15 th floor
City:	Jakarta
State/Region:	Jakarta
Postfix/ZIP:	12930
Country:	Indonesia
Telephone:	+62 21 52962011
FAX:	+62 21 52962102
E-Mail:	tim.mackay@holcim.com
URL:	
Represented by:	Tim Macay
Title:	CEO/President Director
Salutation:	Mr.
Last Name:	Macay
Middle Name:	-
First Name:	Tim
Department:	-
Mobile:	+62 811 167343
Direct FAX:	+62 21 52962102
Direct tel:	+62 21 52962101
Personal E-Mail:	tim.mackay@holcim.com

Organization:	Holcim Group Support Ltd
Street/P.O. Box:	Hagenholzstrasse 85
Building:	-
City:	Zürich
State/Region:	Zürich
Postfix/ZIP:	8050
Country:	Switzerland
Telephone:	+41 58 858 8235
FAX:	+41 58 858 8234
E-Mail:	bruno.vanderborght@holcim.com
URL:	-
Represented by:	Bruno Vanderborght
Title:	Dr.
Salutation:	Mr.
Last Name:	Vanderborght
Middle Name:	-
First Name:	Bruno
Department:	Corporate Industrial Ecology
Mobile phone:	+41 79 249 6763



Direct FAX:	+41 58 858 8235
Direct phone:	+41 58 858 8234
Personal E-Mail:	bruno.vanderborght@holcim.com



Annex 2

INFORMATION REGARDING PUBLIC FUNDING

No public funding has been received for the project activity.

**Annex 3****BASELINE INFORMATION**

All data is included in the PDD. Additional information is detailed in the calculation data base.

Annex 4**MONITORING INFORMATION**

All data is included in the PDD. Additional information is detailed in the calculation data base.

Here below the estimation of the percentage of each fuel in the project activity for the 3 kilns.

CC2	2007	2008	2009	2010	2011	2012	2013	2014	2015	2016
Coal	87.40	85.08	76.60	70.38	62.88	62.88	62.88	62.88	62.88	62.88
Light oil /Diesel	2.15	2.15	2.15	2.15	2.15	2.15	2.15	2.15	2.15	2.15
Waste oil	0	0	0	0	0	0	0	0	0	0
CPO	0.60	0.60	0.60	0.60	0.60	0.60	0.60	0.60	0.60	0.60
Biomass	9.85	12.17	20.66	26.87	34.37	34.37	34.37	34.37	34.37	34.37
Sorted waste	nd	nd	nd	nd	nd	nd	nd	nd	nd	nd

NR3	2007	2008	2009	2010	2011	2012	2013	2014	2015	2016
Coal	92.66	86.59	77.53	73.12	63.66	63.66	63.66	63.66	63.66	63.66
Light oil /Diesel	2.87	2.87	2.87	2.87	2.87	2.87	2.87	2.87	2.87	2.87
Waste oil	3.47	3.34	3.34	3.36	3.34	3.34	3.34	3.34	3.34	3.34
CPO	0.60	0.60	0.60	0.60	0.60	0.60	0.60	0.60	0.60	0.60
Biomass	0.40	6.60	15.66	20.06	29.53	29.53	29.53	29.53	29.53	29.53
Sorted waste	nd	nd	nd	nd	nd	nd	nd	nd	nd	nd

NR4	2007	2008	2009	2010	2011	2012	2013	2014	2015	2016
Coal	92.33	89.65	87.96	76.59	62.98	62.98	62.98	62.98	62.98	62.98
Light oil /Diesel	1.71	1.71	1.71	1.71	1.71	1.71	1.71	1.71	1.71	1.71
Waste oil	0.00	0.00	0.00	0.00	0.00	0.00	0.00	0.00	0.00	0.00
CPO	0.60	0.60	0.60	0.60	0.60	0.60	0.60	0.60	0.60	0.60
Biomass	5.37	8.04	9.73	21.10	34.71	34.71	34.71	34.71	34.71	34.71
Sorted waste	nd	nd	nd	nd	nd	nd	nd	nd	nd	nd
